

 **POWERTEC®**

P-BT16

Manual

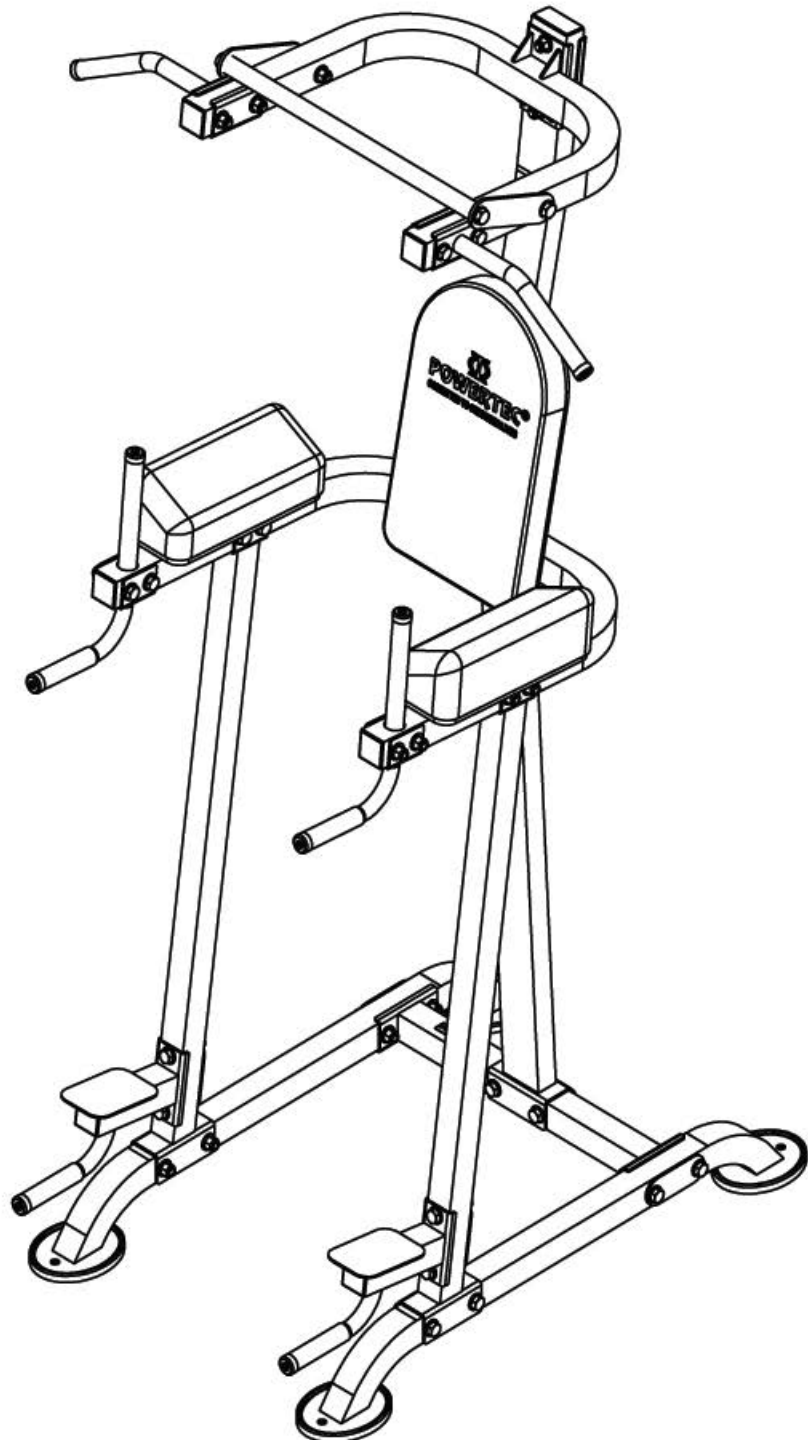

BASIC TRAINER

Thank you for purchasing your new Powertec equipment.
To maximize the use of this Equipment, please take a moment to study, understand and familiarize with the assembly instructions and follow the sequence of steps as provided in the manual.

Because of our products unique features, this manual was created to provide you with information on how to assemble and properly maintain your equipment.

Table of Contents

| | |
|--|------|
| Introduction and Weight Capacities..... | 2 |
| Safety Instructions, Warnings and Cautions | 3 |
| Maintenance Tips..... | 4 |
| Tools Required for Assembly..... | 5 |
| Hardware List..... | 6 |
| Parts List..... | 7 |
| Exploded Diagram..... | 8 |
| Assembly Steps..... | 9-11 |
| Featured Exercises..... | 12 |
| Warranty Certificate..... | 13 |
| Warranty Registration Card..... | 14 |

P-BT16 Basic Trainer

Weight Capacities

Chin Up and Dip Bars 400 Lbs.

Featured Exercises

Chin Ups Dips Leg Raise Push Ups

Recommended Strength Classic Systems

| | | | |
|--------|----------------------------|----------|--------------------------|
| L-SC16 | Levergym Squat Calf | L-CDA+16 | LeverGym Chin/Dip Assist |
| P-HC16 | Dual Hyperextension Crunch | P-LM16 | Powertec Lat Machine |
| P-LP16 | Powertec Leg Press | | |

SAFETY INSTRUCTIONS, WARNINGS AND CAUTIONS



It is recommended that users of this equipment receive a thorough medical exam before commencing any exercise program. This is especially important if you have never Exercised and or are over the age of 35, are pregnant or suffer from any health issues.

Read All Warnings and Cautions on this Manual and on the Product

This product should only be used after a thorough review of the Owner's Manual.

Keep children away from the product when in use.

Set up and operate the product on a solid level surface.

Do not set up the product on loose rugs or uneven surfaces.

Make sure adequate space is available to exercise and move around the product.

Inspect product before and after each use, inspect for worn out or loose parts, repair or replace as needed.

This equipment meets industry safety standards for stability when used for the intended exercise. Do not allow straps, resistance bands or other means to be attached to the framework of this equipment to perform stretching or body weight exercises as it can result to equipment instability and lead to serious injuries.

Always choose a workout that best fits your needs, physical strength and flexibility Levels, know your limits and your product limits and train within them.

Always wear proper footwear with nonskid rubber soles such, running, walking or Cross training shoes that fit well and provide support.

Do not exercise bare foot or in socks.

Always use common sense when exercising.



MAINTENANCE



The safety and performance of this product can be maintained only if it is examined regularly for damage and normal wear. Examine the equipment before each use for damage and wear. Replace damaged and worn components immediately or put the equipment out of use until repaired.

Inspect Daily / Before Each Use!

Inspect system. Make sure it is in good condition and operates smoothly. If you find damage, **DO NOT USE**. Contact your authorized Powertec dealer or Powertec Customer Service Center for assistance.

Inspect Daily / After Each Use!

Clean system with a clean, dry cloth. Use a mild detergent or spray on upholstery. Do Not use cleansers containing enzymes.

Inspect Weekly!

Clean your system fully with a clean and ammonia based cleaner. Touch up any scratches with touch-up paint to prevent rust, if necessary.

Inspect Monthly!

Examine the frame for signs of cracking or permanent bending. Do not use the equipment if you see this. Contact Powertec Customer Service Immediately. If you have any questions on the correct use or maintenance of this equipment, call your authorized distributor or Powertec Customer Service at 800-250-6665

Our Customer Service Mission:

“Committed to Stronger Lives”

By providing friendly and understanding service.

Tools Required for Assembly

 POWERTEC®



M6 Allen Wrench



Wrenches
13 mm = 1/2"
19 mm = 3/4"
21 mm = 13/16"



8" Adjustable Wrench

HARDWARE LIST

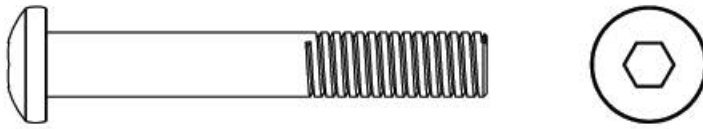

Part No. 18 Hex Bolt 3/8"x2 1/2"



Part No. 19 Hex Bolt 3/8"x3/4"

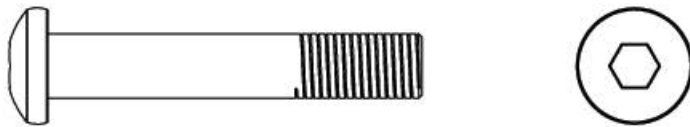

Part No. 20 Hex Bolt 3/8"x2 1/4"



Part No. 21 Hex Bolt 1/2"x3 1/8"

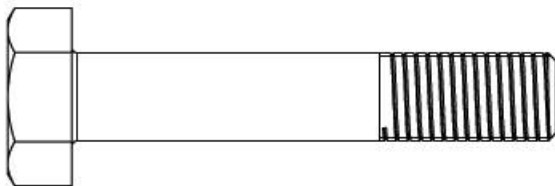

Part No. 22 Hex Bolt 1/2"x2 3/4"

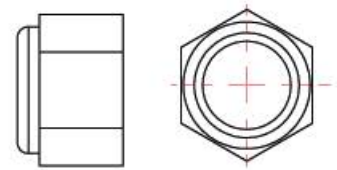

Part No. 26 Nut 1/2"

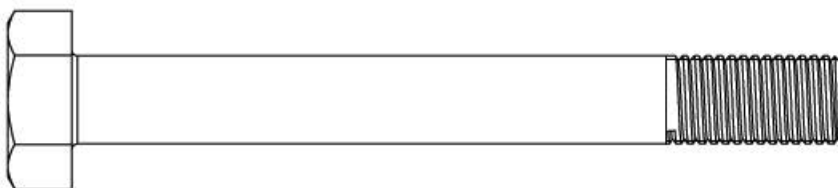

Part No. 25 Hex Bolt 1/2"x4 1/4"

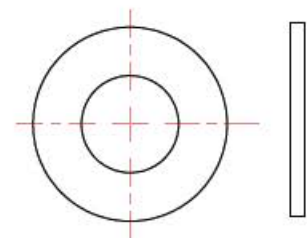

Part No. 27 Washer 1/2"

P-BT16

BASIC TRAINER

PARTS LIST



POWERTEC®

| Part No. | Description: | Qty. |
|----------|--|------|
| 1 | Side Base Tubes | 2 |
| 2 | Rear Base Tube | 1 |
| 3 | Front-Side Support Tubes | 2 |
| 4 | Rear Support Tube | 1 |
| 5 | Lower U-Shape Arm | 1 |
| 6 | Backrest Pad Support Tube | 1 |
| 7 | Upper U Shape Arm | 1 |
| 8 | Pull Up Handles | 2 |
| 9 | Handles | 2 |
| 10 | Foot Support / Lower Handles | 2 |
| 11 | Reinforcement Plate | 1 |
| 12 | Linkage Plate | 2 |
| 13 | Close Grip Bar | 1 |
| 14 | Reinforcement Plates / Pull Up Handles | 2 |
| 15 | Reinforcement Plates / Foot Support | 4 |
| 16 | Backrest Pad | 1 |
| 17 | Arm Rest Pads | 2 |
| 18 | Hex Bolts 3/8" x 2 1/2" | 4 |
| 19 | Hex Bolts 3/8" x 3/4" | 3 |
| 20 | Hex Bolts 3/8" x 2 1/4" | 2 |
| 21 | Hex Bolt 1/2" x 3 1/8" | 26 |
| 22 | Hex Bolt 1/2" x 2 3/4" | 2 |
| 23 | Hex Bolt 1/2" x 1" | 2 |
| 24 | Hex Bolt 1/2" x 3 3/8" | 2 |
| 25 | Hex Bolt 1/2" x 4 1/4" | 2 |
| 26 | Nut 1/2" | 32 |
| 27 | Washer 1/2" | 66 |

P-BT16

BASIC TRAINER

EXPLODED DIAGRAM

POWERTEC[®]

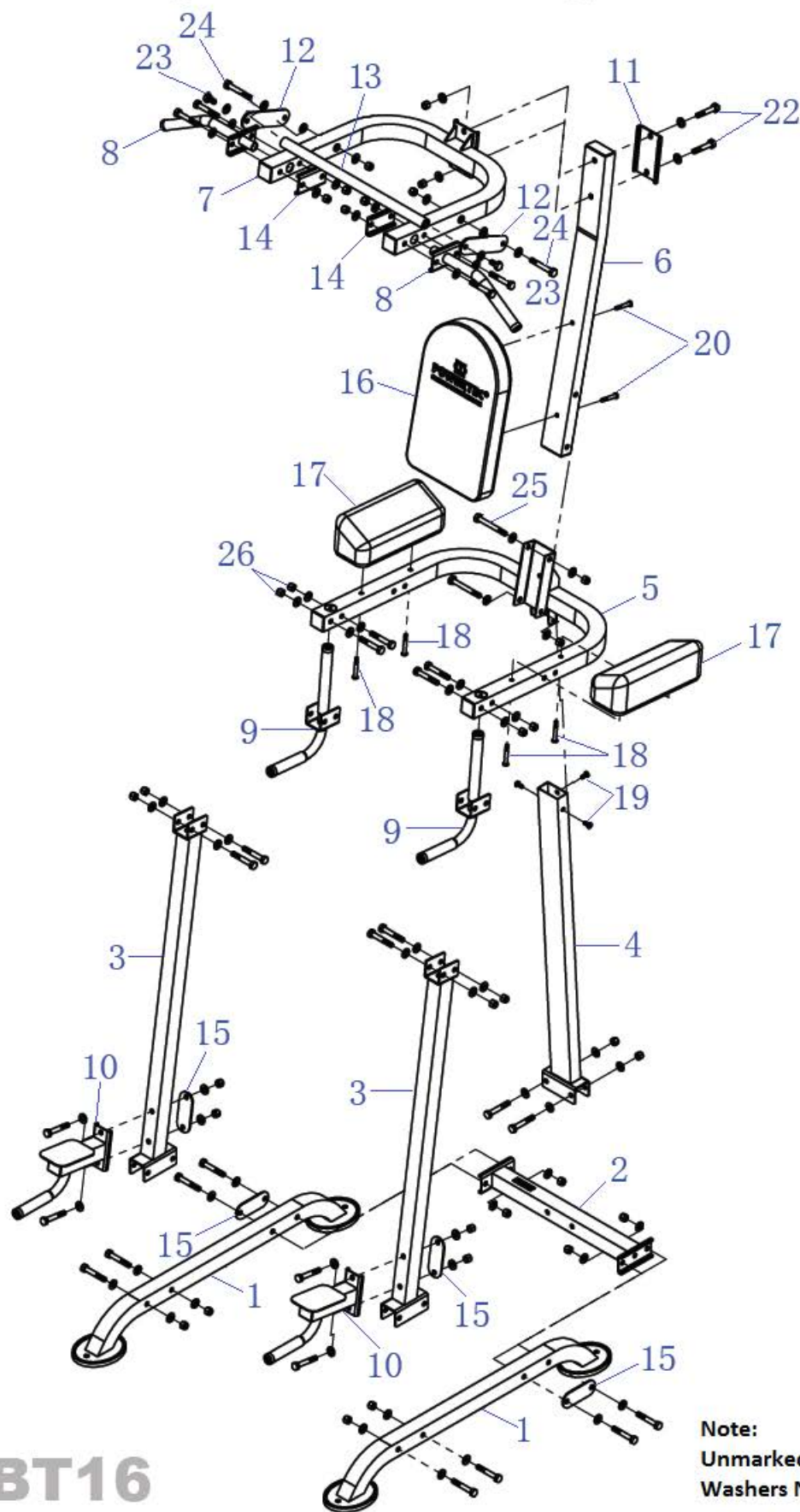

P-BT16
BASIC TRAINER

Note:
Unmarked Hardware is: Bolts No. 21
Washers No. 27 and Nuts No. 26

ASSEMBLY ONE

POWERTEC[®]

Step 1

Install Rear Base Tube No. 2 to Side Base Tubes No. 1 Using Linkage Plates No. 15, Bolts No. 21, Washers No. 27 and Nuts No. 26

Step 2

Install Support Tube No. 4 on to Rear Base Tube No. 2 Using Bolts No. 21, Washers No. 27 and Nuts No. 26

Step 3

Install Front Side Support Tubes No. 3 on to Base Tubes No.1 using Bolts No. 21, Washers No. 27 and Nuts No. 26

Step 4

Install Foot Support / Handles No. 10 on to Support Tubes No. 3 Using Linkage Plates No. 15, Bolts No. 21, Washers No. 27 and Nuts No. 26

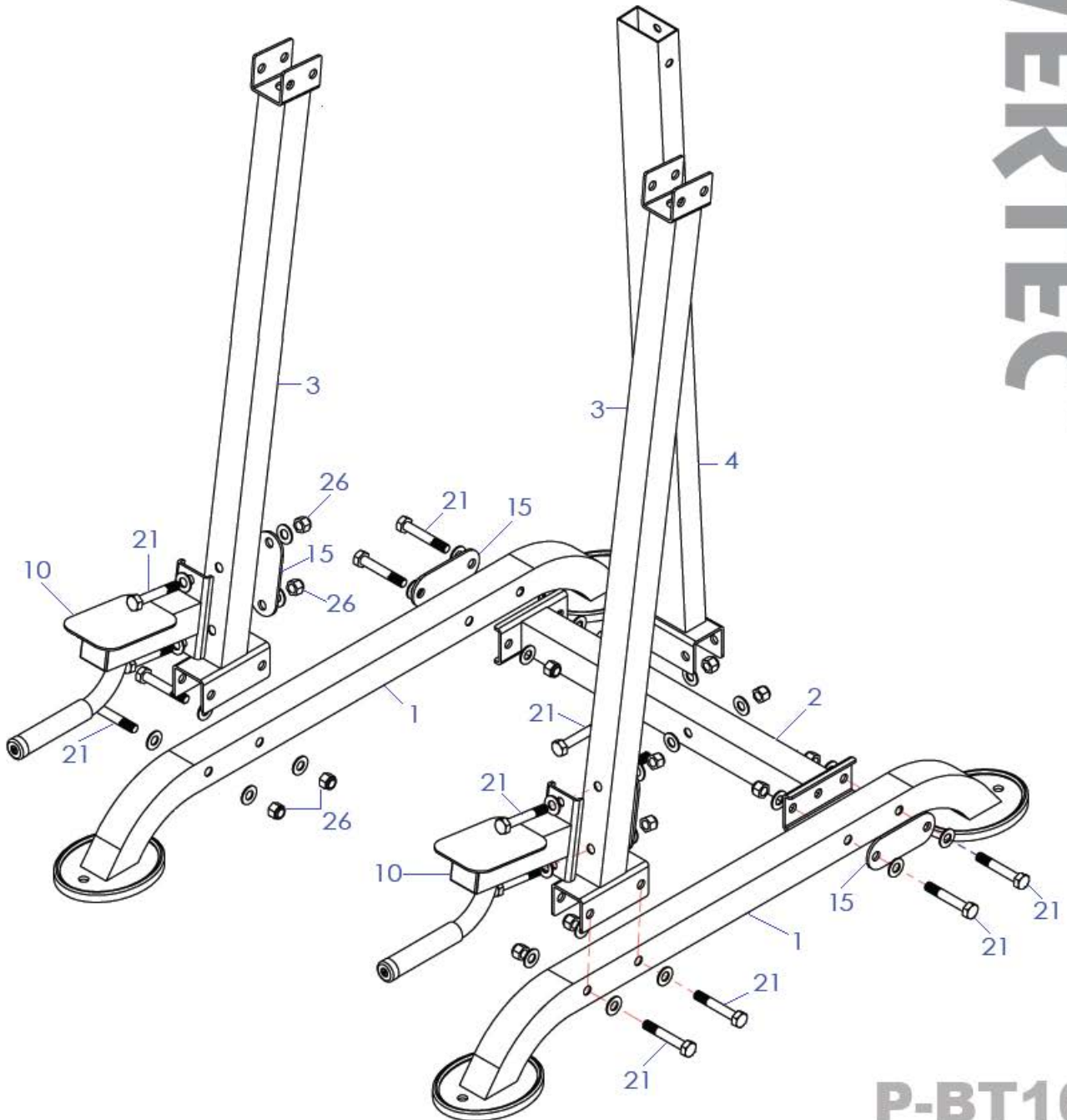

P-BT16

BASIC TRAINER

ASSEMBLY TWO

Step 1

Install Lower U Shape Arm to Support Tubes No. 3 Use Bolts No. 21, Washers No. 27 and Nuts No. 26 and Use Bolts No. 19 to Connect it to Rear Support Tube No. 4

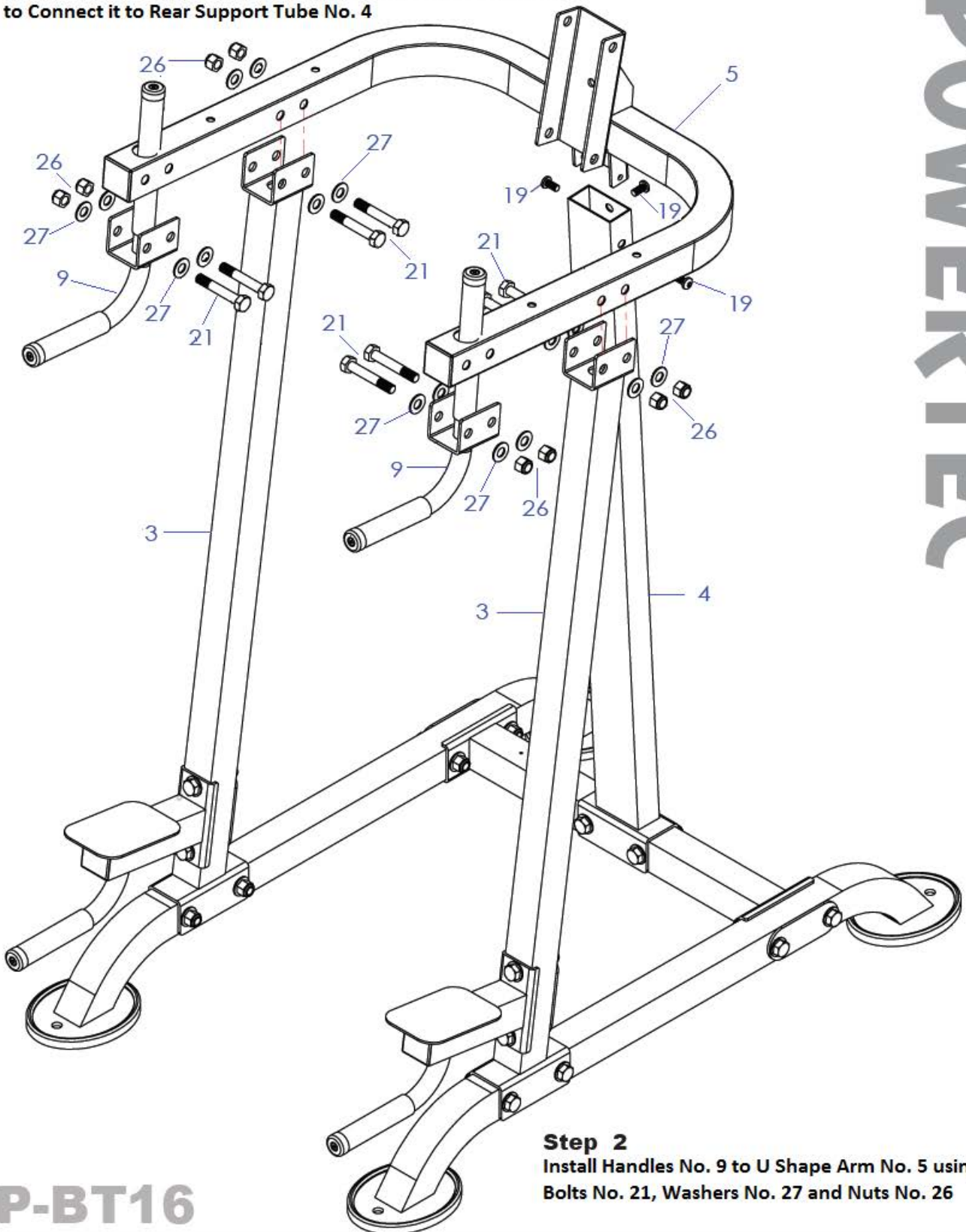

Step 2

Install Handles No. 9 to U Shape Arm No. 5 using Bolts No. 21, Washers No. 27 and Nuts No. 26

P-BT16

BASIC TRAINER

POWERTEC[®]

ASSEMBLY THREE

POWERTEC[®]

Step 1

Attached Backrest Pad Support Tube No. 6 on to U Shape Arm No. 5 Using Bolts No. 25, Washers No. 27 and Nuts No. 26

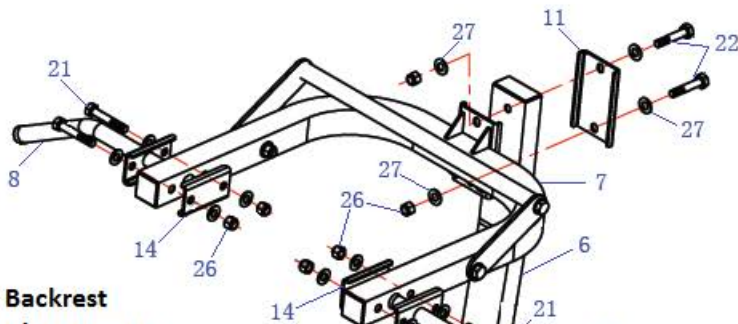

Step 2

Install Upper U Shape Arm No. 7 onto Backrest Pad Support Tube No. 6 Using linkage Plate No. 11, Bolts No. 22, Washers No. 27 and Nuts No. 26

Step 3

Install Pull Up Handles No. 8 to U Shape Arm No. 7 Using Reinforcement Plate No. 14, Bolts No. 21, Washers No. 27 and Nuts No. 26

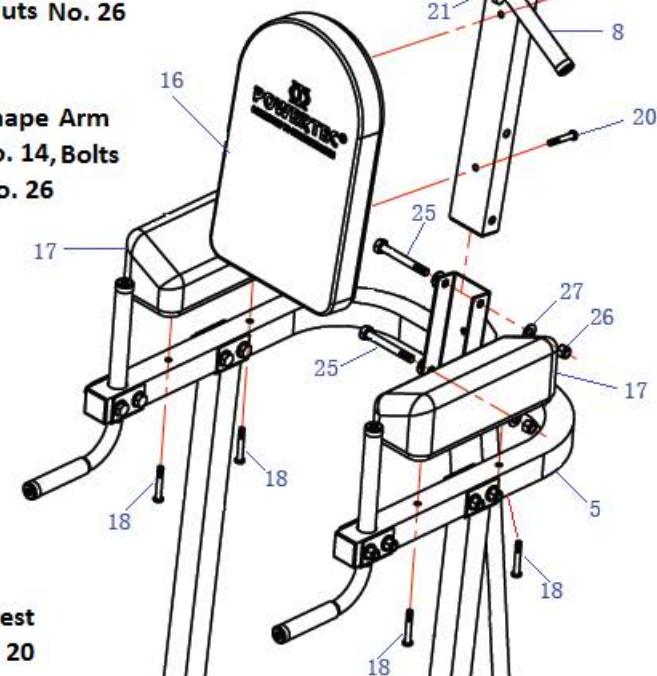

Step 4

Install Backrest Pad No. 16 to Backrest Support Tube No. 6 Using Bolts No. 20

Step 5

Install Arm Rest Pads No. 17 to U Shape Arm No. 5 Using Bolts No. 18

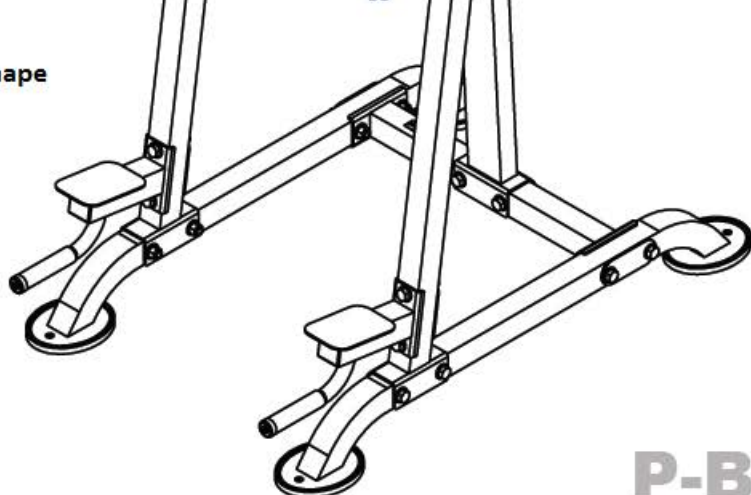

P-BT16

BASIC TRAINER

P-BT16

Exercise Matrix



Chin Ups

Starting Position: Grip the Handles at the top of the Basic Trainer

Pull yourself up until your chin reaches the height of the bar or as far as you can,

Pause briefly before returning to the starting position, repeat exercise routine



Dips

Starting Position: face the machine and place yourself in between the Dip Bars. Grip the Dip Bars and keep your arms fully extended (do not lock your elbows) as you bend your knees, lifting your feet off the ground and crossing your ankles behind you.

Slowly lower yourself until your chest is almost at the level of the Dip Bars.

Do Not Dip too far down.

Pause briefly before returning to the starting position, repeat exercise routine.



Hanging Abdominal Twist

Starting Position: Grip handle bars in mid-section of the Basic Trainer.

As you lift your legs, bend your knees. Keep your legs together and pull your knees up towards one side (alternating sides). Lift until your knees are at or near waist height.

Pause briefly before returning to starting position, repeat exercise routine.



Push-Ups

Starting Position: Grab the Push-Up Handles with your arms fully extended (Do not lock your elbows). And extend your body (facing the floor). Keep your legs, back, neck and head straight and aligned. Curl your toes up and allow the weight to rest on the balls of your feet. Lower yourself by bending at the elbows.

Pause briefly before returning to starting position, repeat exercise routine.

WARRANTY

Serial No.

Thank you for purchasing one of Powertec's products.

Powertec warrants that the Product you have purchased is free from defects in materials and workmanship.

Powertec offers a Lifetime Warranty on Structural Frame.(Excludes Surface Finish).
5 year warranty on Moving Frames (Press Arms and other unspecified moving components).
Two year warranty on Components (Bearings, Locking Pins, Pulleys, Cables, Slide Rods).
One year warranty on Pads, Grips and other unspecified parts.

- All parts are shipped free of charge for first 90 days of date of purchase.
- Warranty is to original purchaser only (excluding dealer). Warranty is not Transferable in the event you sell the product.
- Warranty claims are subject to inspection and are voided if equipment shows Signs of abuse or alterations made other than the ones recommended by Powertec.
- Missing parts must be reported within 30 days from receipt of unit(s).
- Proof of purchase is required; your sales receipt must show date of purchase.
- For more information on the warranty or to obtain warranty service, please contact The appropriate Powertec Customer Service Department in the USA or Europe.

Powertec Inc. USA
2100 E. Artesia Boulevard
Long Beach, CA. 90805 – USA

Powertec Europe
6, Rue de l'Europe
68500 Bergholtz - France

Phone: (800) 250-6665
E-mail: service@powertecfitness.com

Phone: + 33 (0) 3 89 62 56 30
E-mail: contact@powertec-europe.fr

Thank you for giving us the opportunity to fulfill your strength and fitness needs.

POWERTEC® Customer Warranty Information Sheet

Last Name: _____ First Name: _____

Company: _____

Street Address: _____

City: _____ State: _____ Zip Code: _____

Daytime Telephone No: _____ Alternate Telephone No. _____

E-Mail: _____ Date of Purchase: _____ Purchase Price: _____

Dealer Name and Address: _____

Model Name & Code: _____ Optional: Male / Female: _____ Age: _____ Occupation: _____

POWERTEC IS NOT LIABLE IF THE TRAINER SHOULD INJURE THEMSELVES WHILE USING POWERTEC EQUIPMENT OR WHILE PERFORMING THE TRAINING ROUTINE



COMMITTED TO STRONGER LIVES[®]

POWERTEC INC.
2100 East Artesia Boulevard
Long Beach, CA. 90805 - USA

Phone: (800) 250-6665
Fax: (714) 908-0493
service@powertecfitness.com
www.powertecfitness.com

POWERTEC EUROPE
6, Rue de l'Europe
68500 BERGHOLTZ - France

Phone: + 33 (0) 3 89 625 630
Fax: + 33 (0) 3 89 625 631
E-mail: contact@powertec-europe.fr

Return Warranty Registration Card to Appropriate Powertec Address:



Place
Stamp
Here



