

Peak Fitness

OWNER'S MANUAL

PF-FT900H

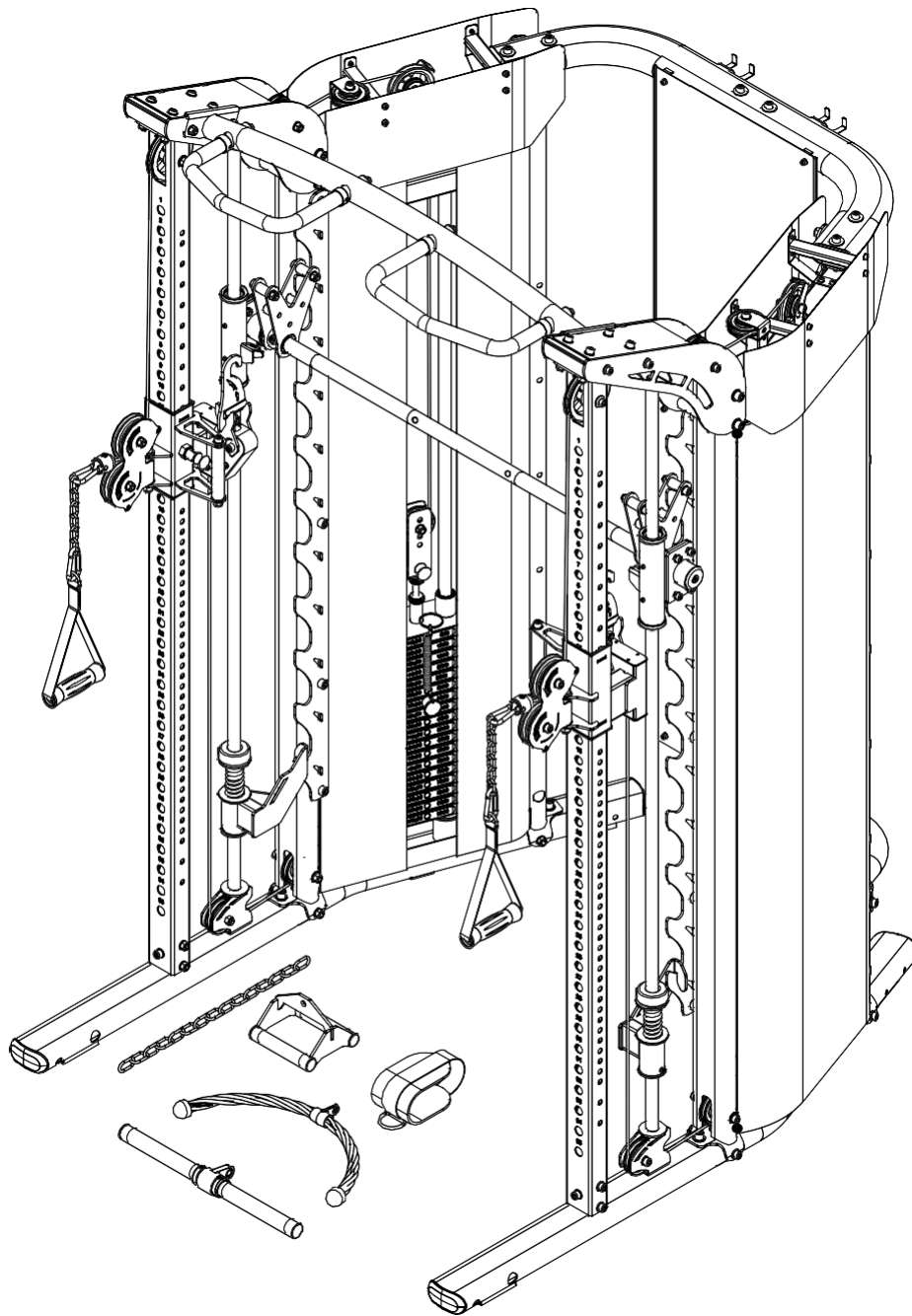

OBS!

Læs alle forholdsregler og instruktioner i denne vejledning, før du bruger dette udstyr.

20230926-V1.0

INDHOLDSFORTEGNELSE

FØR DU BEGYNDER.....	1
VIGTIGE SIKKERHEDSBEMÆRKNINGER.....	2
HARDWARE PAKKE.....	6
MONTERINGSVEJLEDNING.....	9
UDVIDET DIAGRAM... ..	30
DEL LISTE.....	31

FØR DU BEGYNDER

Tak for dit valg af PF-FT900H. Af hensyn til din sikkerhed, bør du læse denne vejledning omhyggeligt, inden du bruger maskinen. Som producent er vi forpligtet til at give dig fuld kundetilfredshed.

SIKKERHEDSMEDDELELSE

FORHOLDSREGLER

Denne træningsmaskine er bygget til optimal sikkerhed. Der gælder dog visse forholdsregler, når du betjener et træningsredskab. Sørg for at læse hele manualen, før du samler eller betjener din maskine. Bemærk især følgende sikkerhedsforanstaltninger:

1. Hold altid børn og kæledyr væk fra maskinen.
Lad være med at efterlade børn uden opsyn i samme rum med maskinen.
2. Kun én person ad gangen bør bruge maskinen.
3. Hvis brugeren oplever svimmelhed, kvalme, brystmerter eller andre unormale symptomer, STOP træningen med det samme.
KONSULTER STRAKS EN LÆGE.
4. Placer maskinen på en jævn vandret overflade.
BRUG IKKE maskinen i nærheden af vand eller udendørs.
5. Hold hænderne væk fra alle bevægelige dele.
6. Brug altid passende træningstøj, når du træner.
Løb eller aerobic sko er også anbefalet, når du bruger maskinen.
7. Brug kun maskinen til dens tilsigtede brug som beskrevet i denne vejledning.
Brug **IKKE** tilbehør, der ikke er anbefalet af producenten.
8. Anbring ikke skarpe genstande omkring maskinen.
9. Handicappede personer bør ikke bruge maskinen uden en kvalificeret person eller læge til stede.
10. Brug ikke maskinen, hvis maskinen ikke fungerer korrekt.
11. Maks brugervægt: 160 kg.
12. Maks belastning (inkl. Bruger): 360 kg.

ADVARSEL:

FØR DU BEGYNDER ET TRÆNINGSPROGRAM, SØG DIN LÆGE. DETTE ER SÆRLIG VIGTIGT FOR PERSONER OVER 35 ALDER ELLER PERSONER MED EKSISTERENDE SUNDHEDSPROBLEMER.

LÆS ALLE INSTRUKTIONER, FØR DU BRUGER ETHVERT FITNESSUDSTYR. VI PÅTAGER SIG INTET ANSVAR FOR PERSONSKADE ELLER EJENDOMSSKADE OPHOLDT AF ELLER VED BRUGEN AF DETTE PRODUKT.

GEM DISSE INSTRUKTIONER.

Importør:

Fitnessgruppen A/S

www.fitnessgruppen.dk

Assembled Dimension: 1320mm x 1560mm x 2180mm

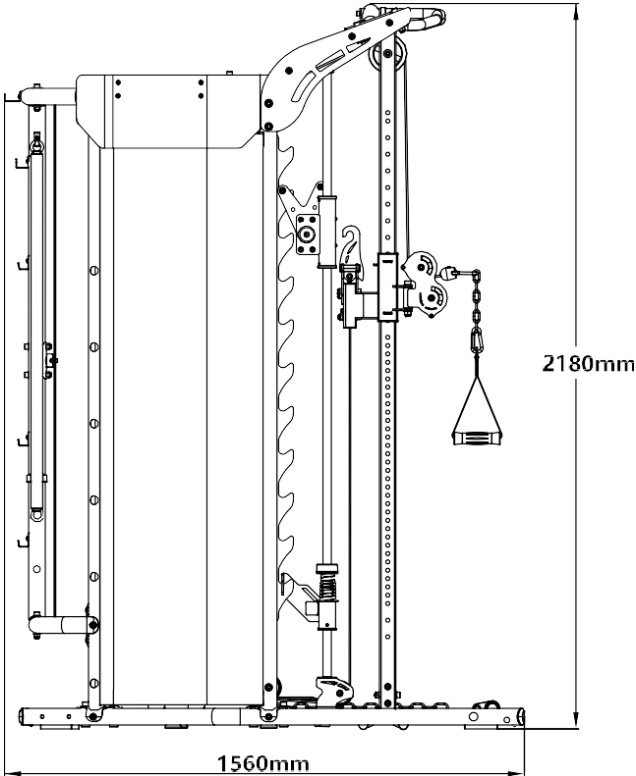
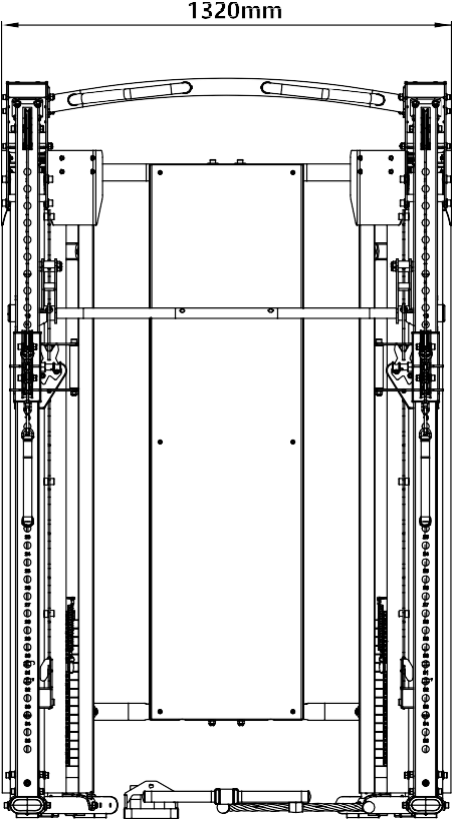

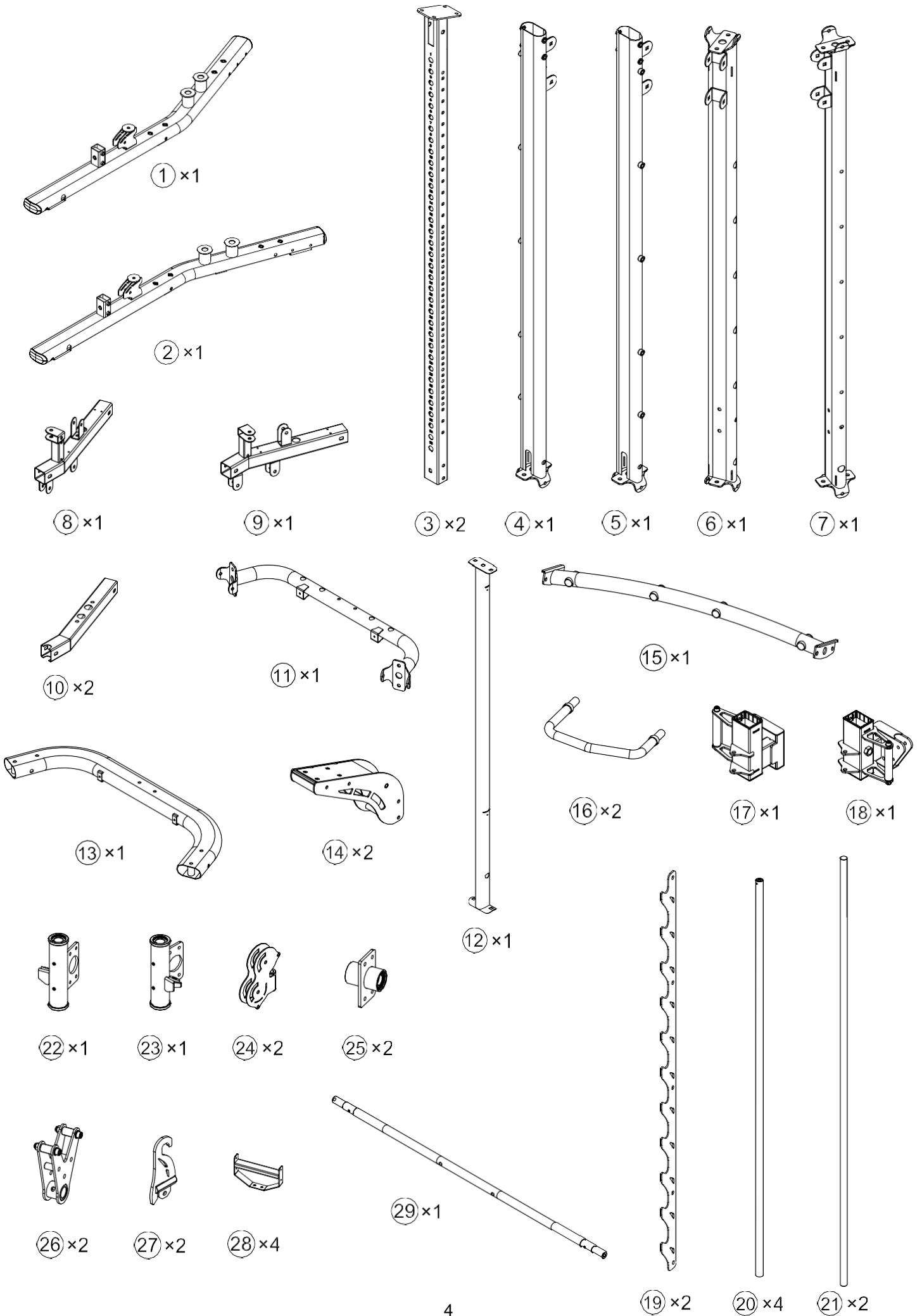

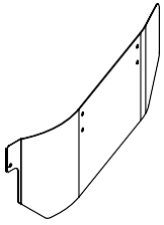

30 x 1

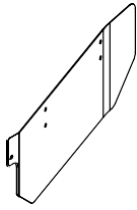

31 x 1

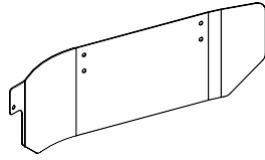

32 x 1

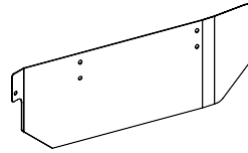

33 x 1



34 x 4

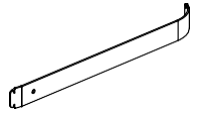

35 x 4

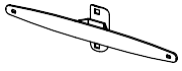

37 x 1



41 x 2



42 x 4



43 x 2



45 x 2



46 x 5



47 x 4



49 x 2

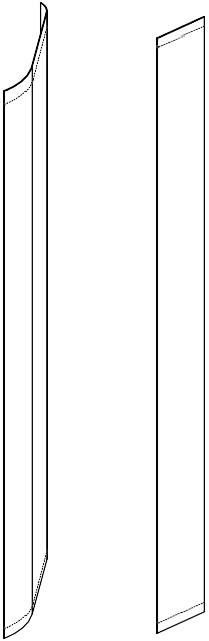

38 x 2

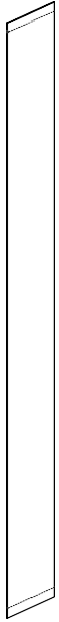

39 x 4

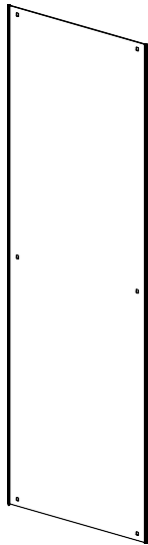

40 x 1



58 x 1



60 x 2

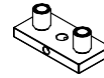

62 x 2

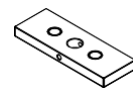

63 x 34



64 x 2



61 x 2



67 x 1



68 x 1



69 x 6



72 x 2



73 x 6



74 x 14



75 x 4



76 x 2

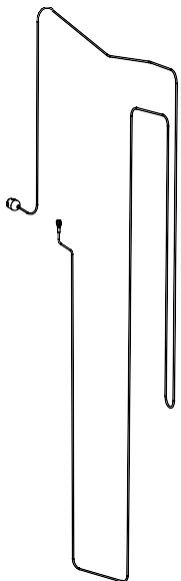

54 x 2



65 x 1

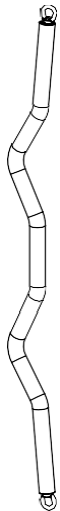

66 x 1



80 x 1



79 x 2



81 x 2



82 x 1



83 x 1



84 x 4



93 x 2



113 x 2

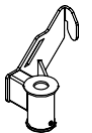

135 x 1



136 x 1



137 x 2

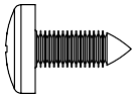

92 × 10

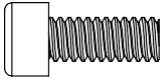
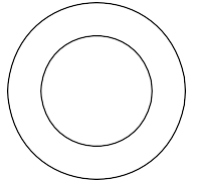
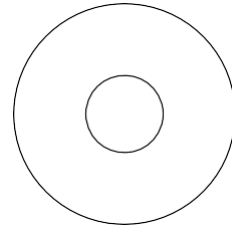
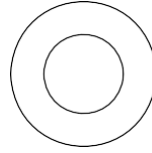
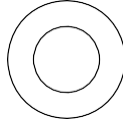

96 × 34

120 × 36

121 × 16

122 × 132

123 × 14

124 × 20

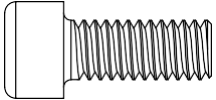

99 × 2

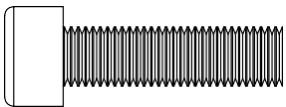
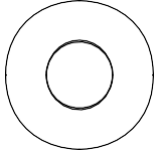
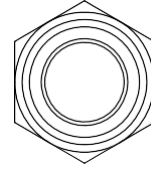
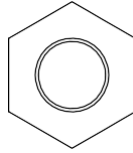
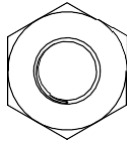

100 × 8

125 × 8

126 × 76

127 × 2

128 × 2

129 × 2



101 × 2



134 × 2

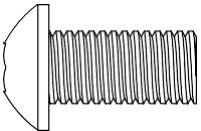

102 × 4

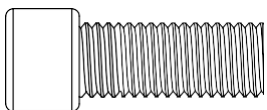

103 × 4

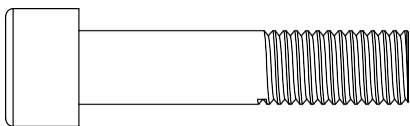

104 × 12

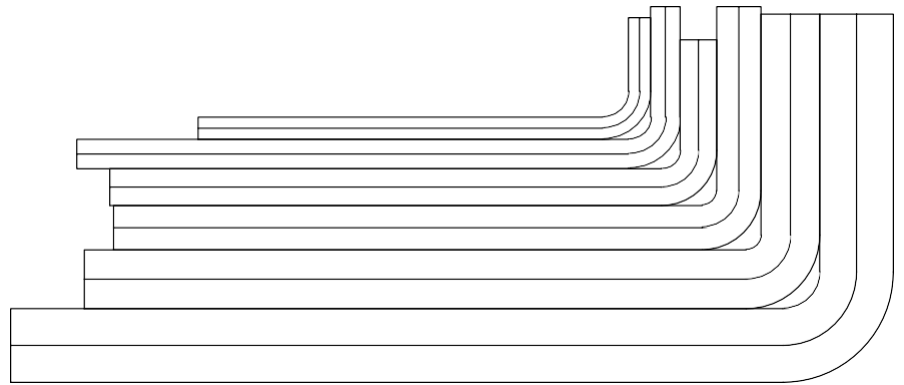

3# 4# 5# 6# 8# 10# × 1

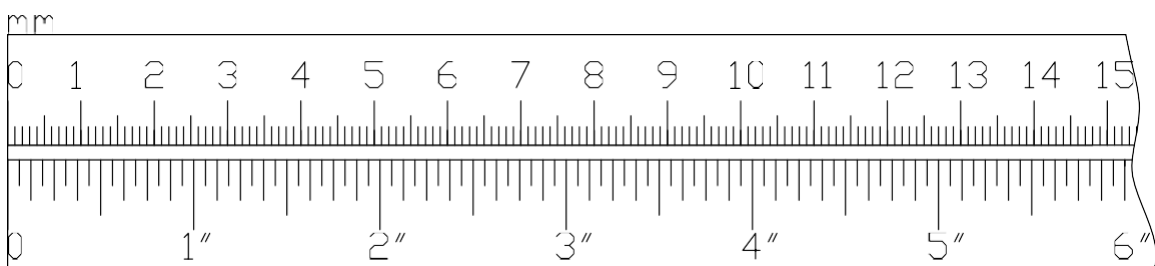

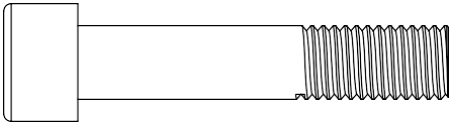

105 × 4

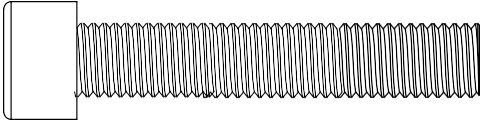
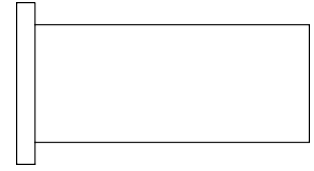
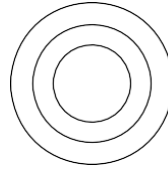

106 × 4

36 × 4

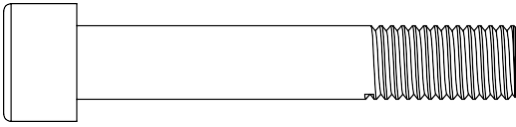

107 × 4

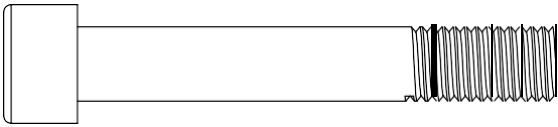
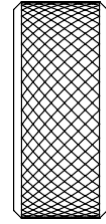
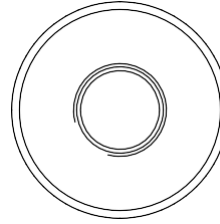

108 × 14

50 × 2

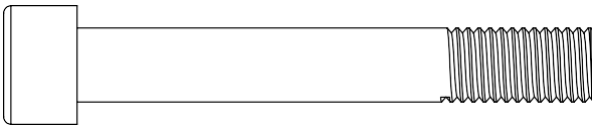

109 × 14

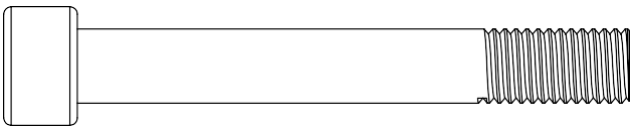
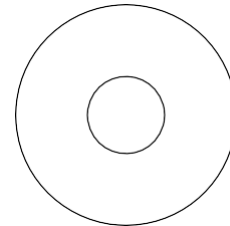

110 × 8

77 × 2

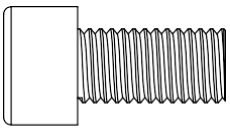

111 × 2

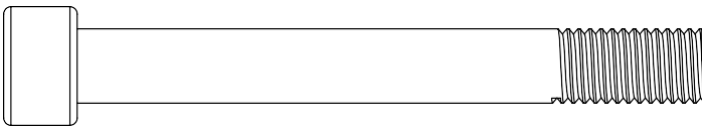
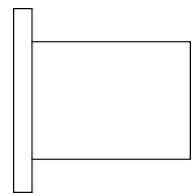
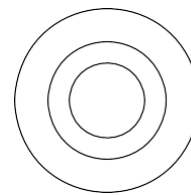

112 × 6

131 × 4

mm

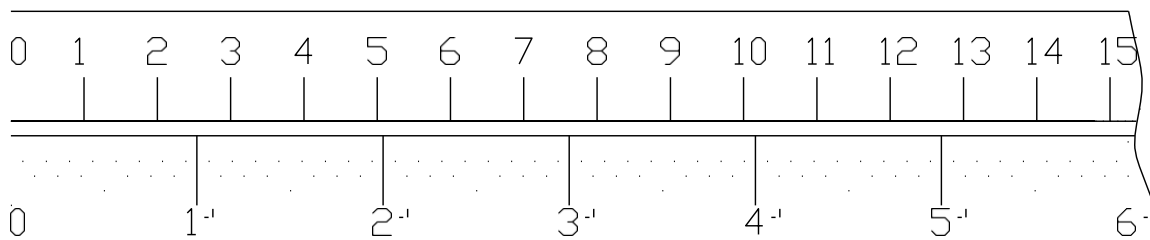

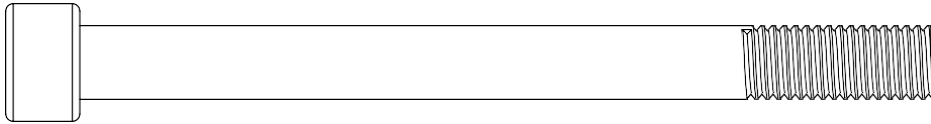

①14 × 2



①15 × 2

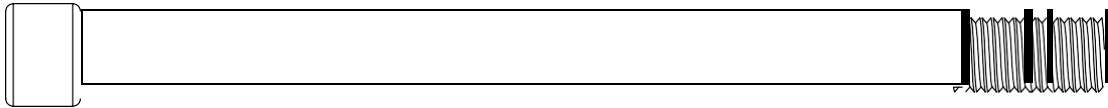

①16 × 4

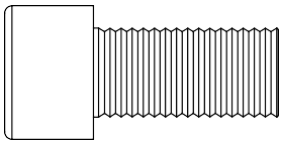

①18 × 26

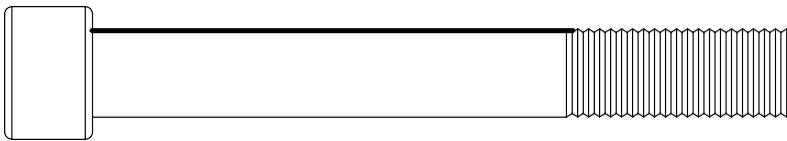

①19 × 2

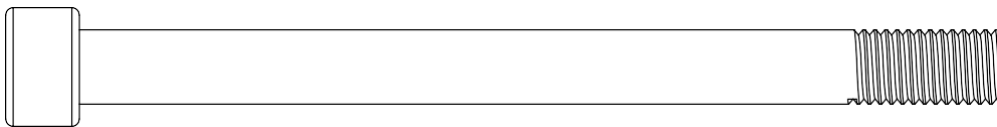

①33 × 8

mm

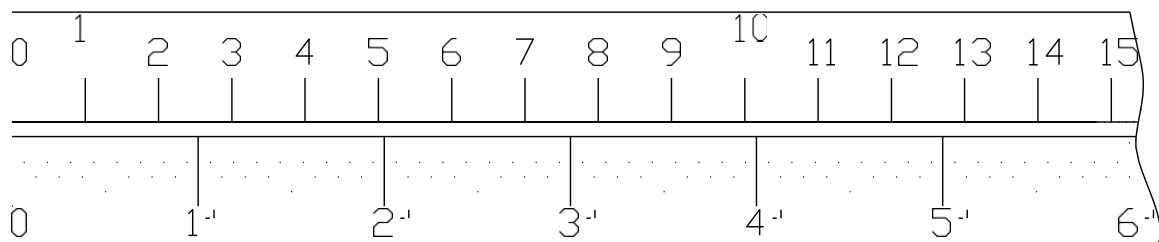

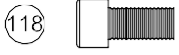

×8 M12×25



×8 Φ12

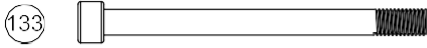

×4 M10×125



×4 M10



×8 Φ10

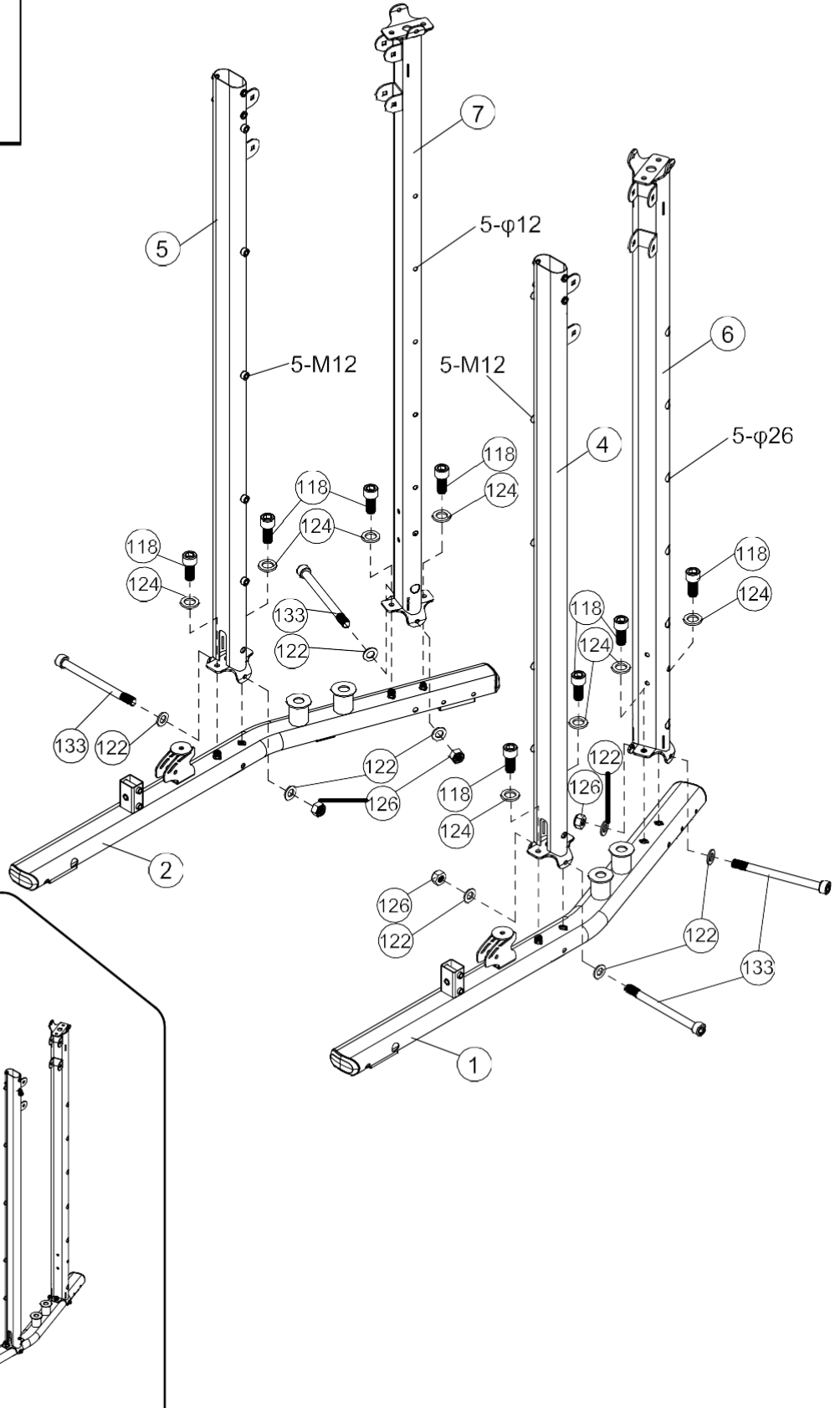
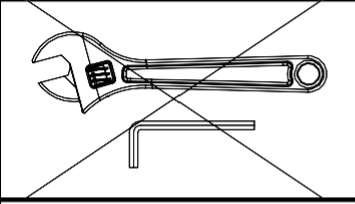

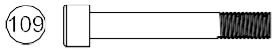

×12 M10×70



×10 Φ30×Φ10.5

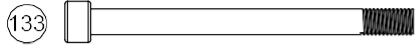

×4 M10×125

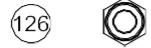

×16 M10



×22 Φ10

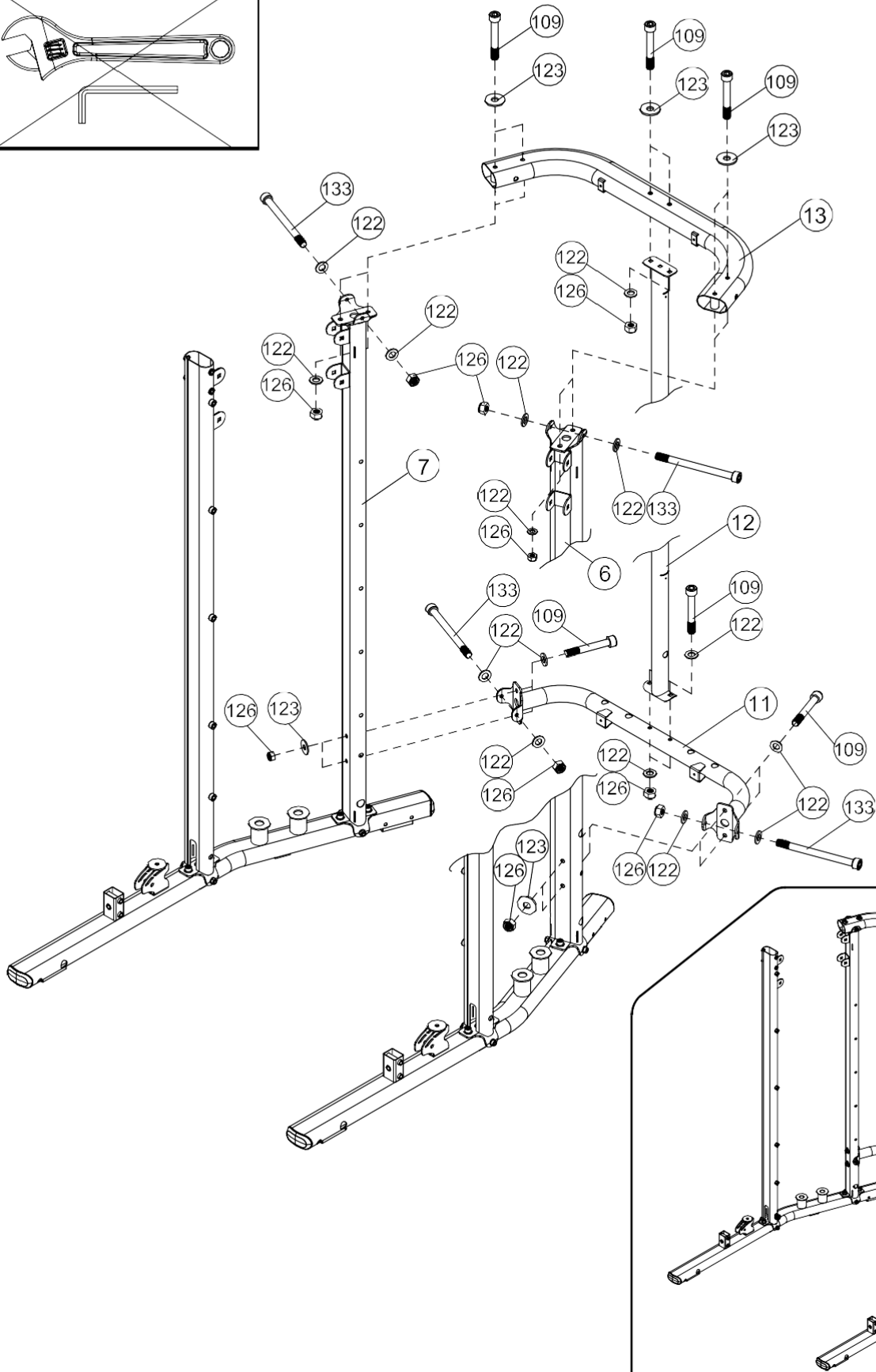
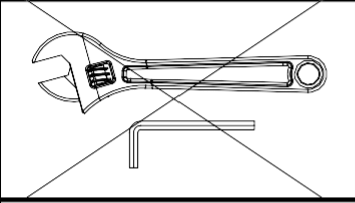



×8 M10×75

126



×8 M10

122



×16 Φ10

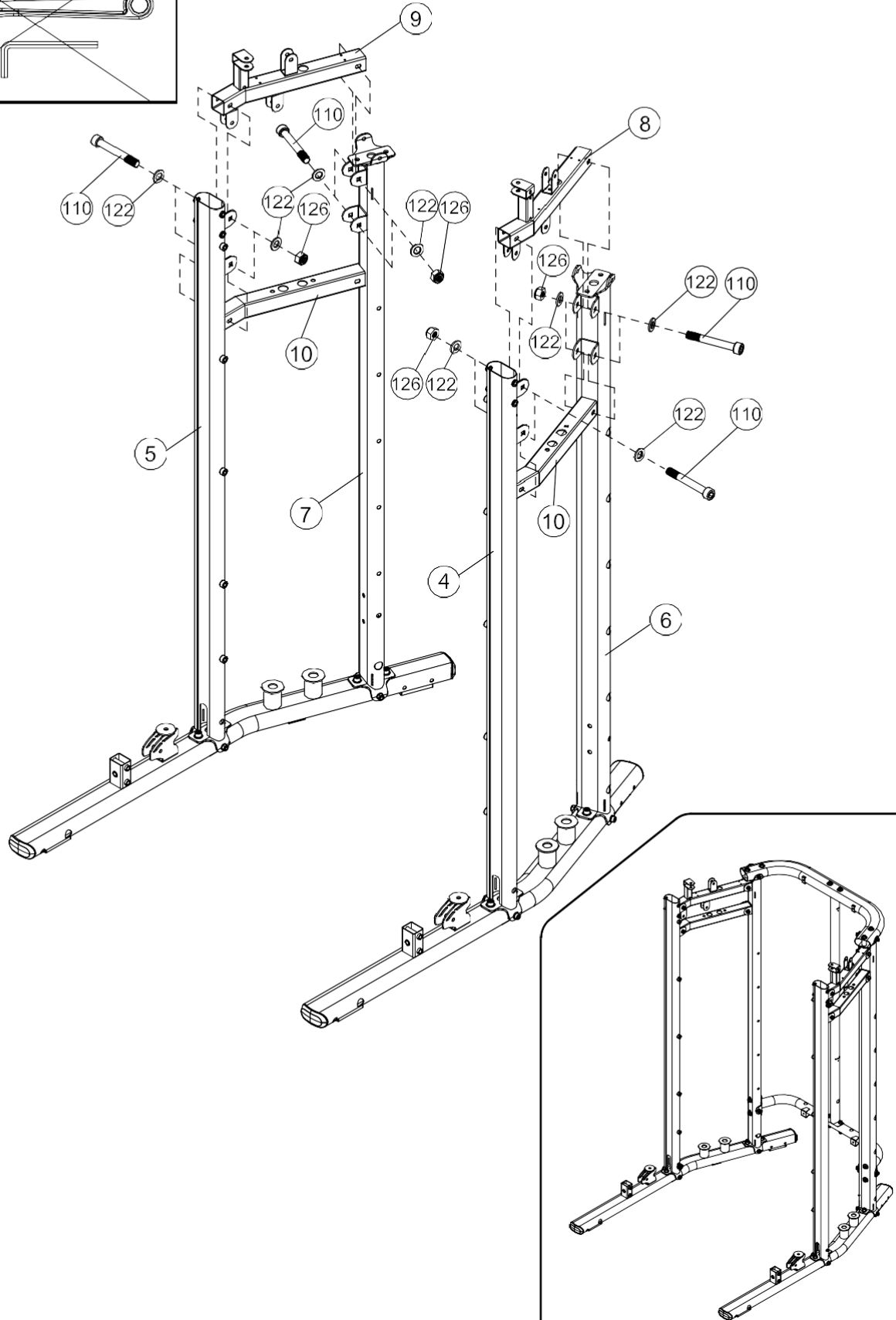
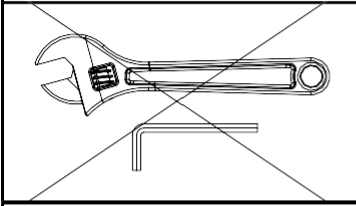

3

108		x2	M10x65	124		x4	Φ12
112		x4	M10x85	126		x6	M10
119		x2	M12x95	127		x2	M12
122		x12	Φ10				

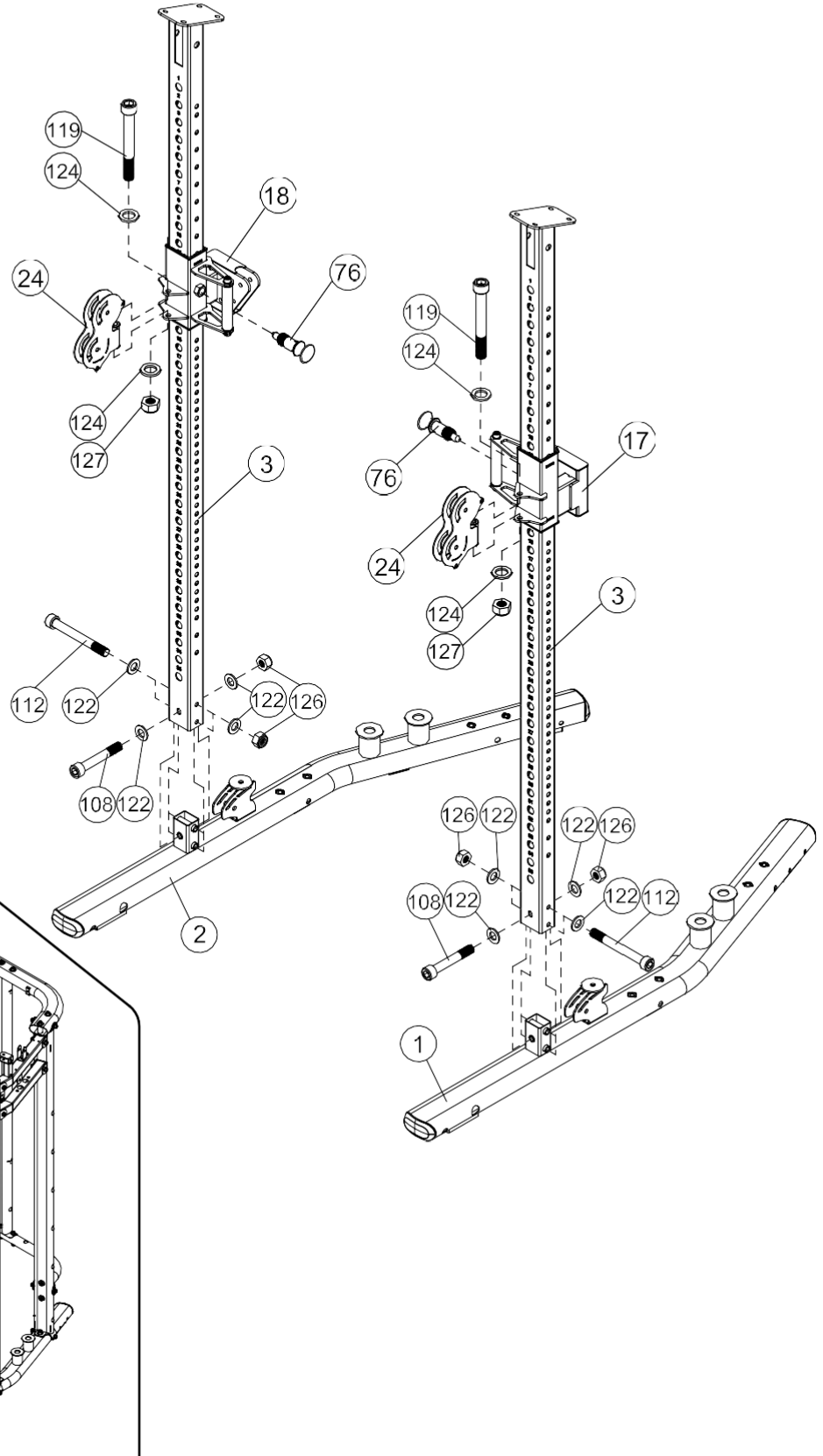
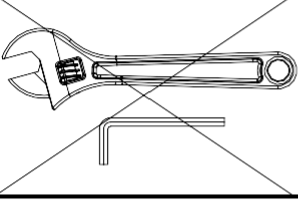

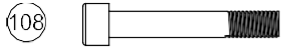

×8 M10×65



×8 M12×25



×16 Φ10







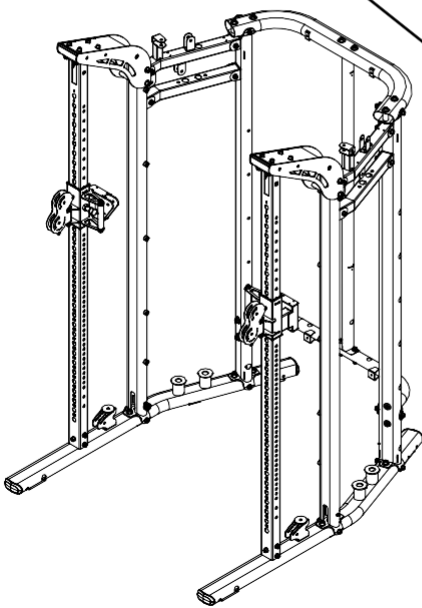
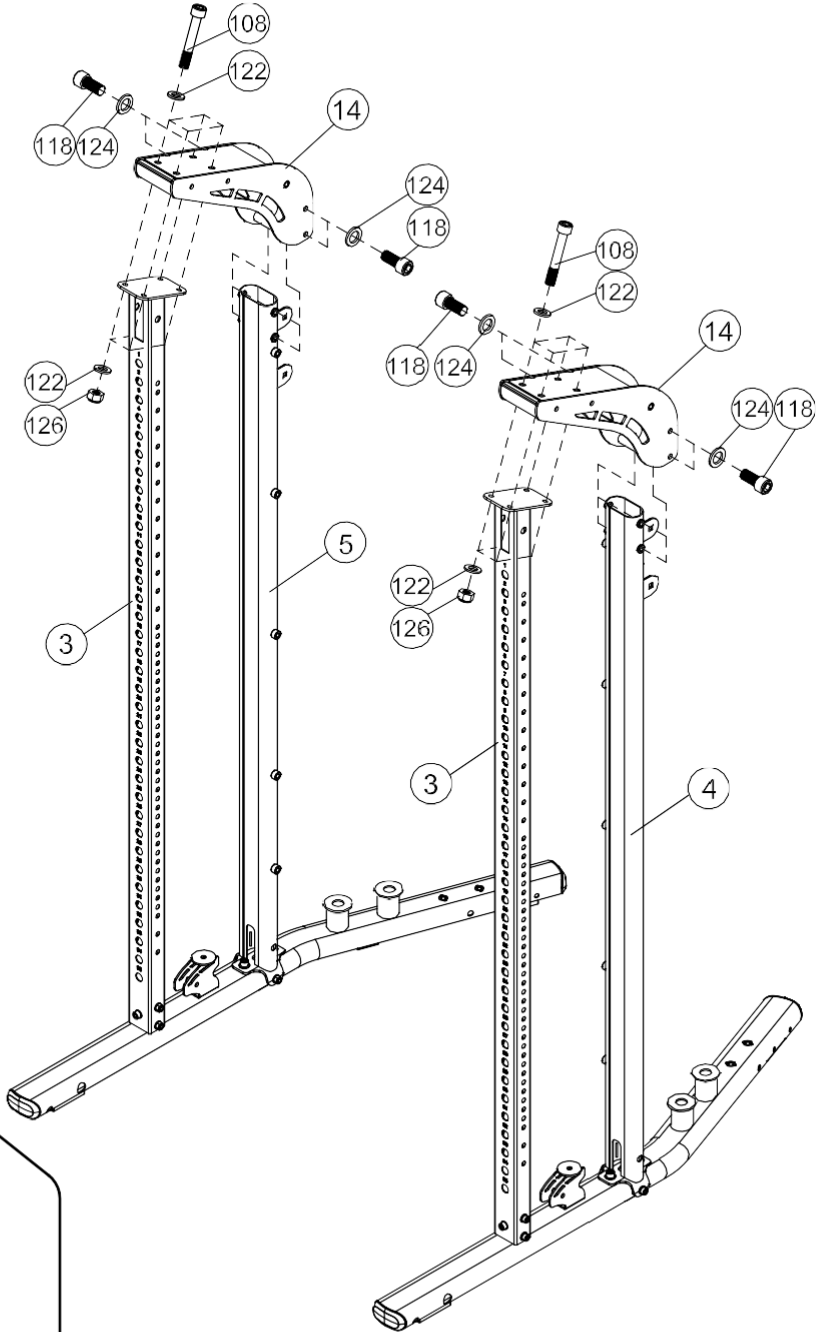
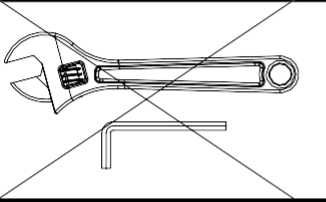

×8 Φ12

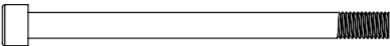

×8 M10



- | | | | | | | | | |
|----|---|----|-----------|----|---|---|----|-----|
| ⑩③ |  | x4 | M10×25 | ⑫② |  | | x8 | Φ10 |
| ⑪⑥ |  | x4 | M10×140 | ⑫⑥ |  |  | x4 | M10 |
| ⑫③ |  | x4 | Φ30×Φ10.5 | | | | | |

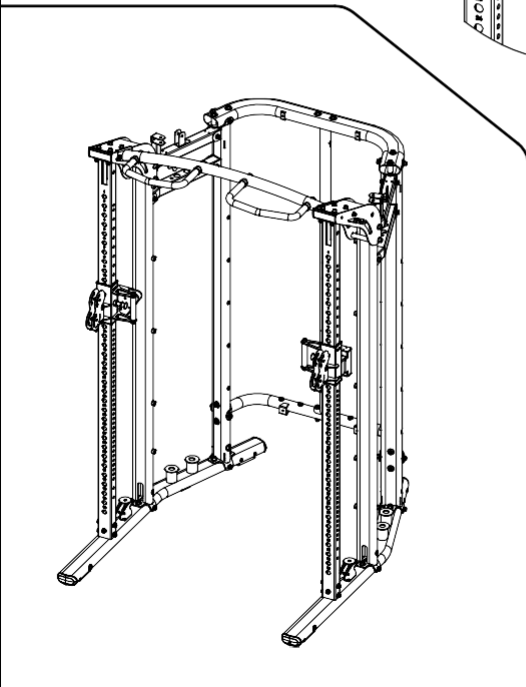
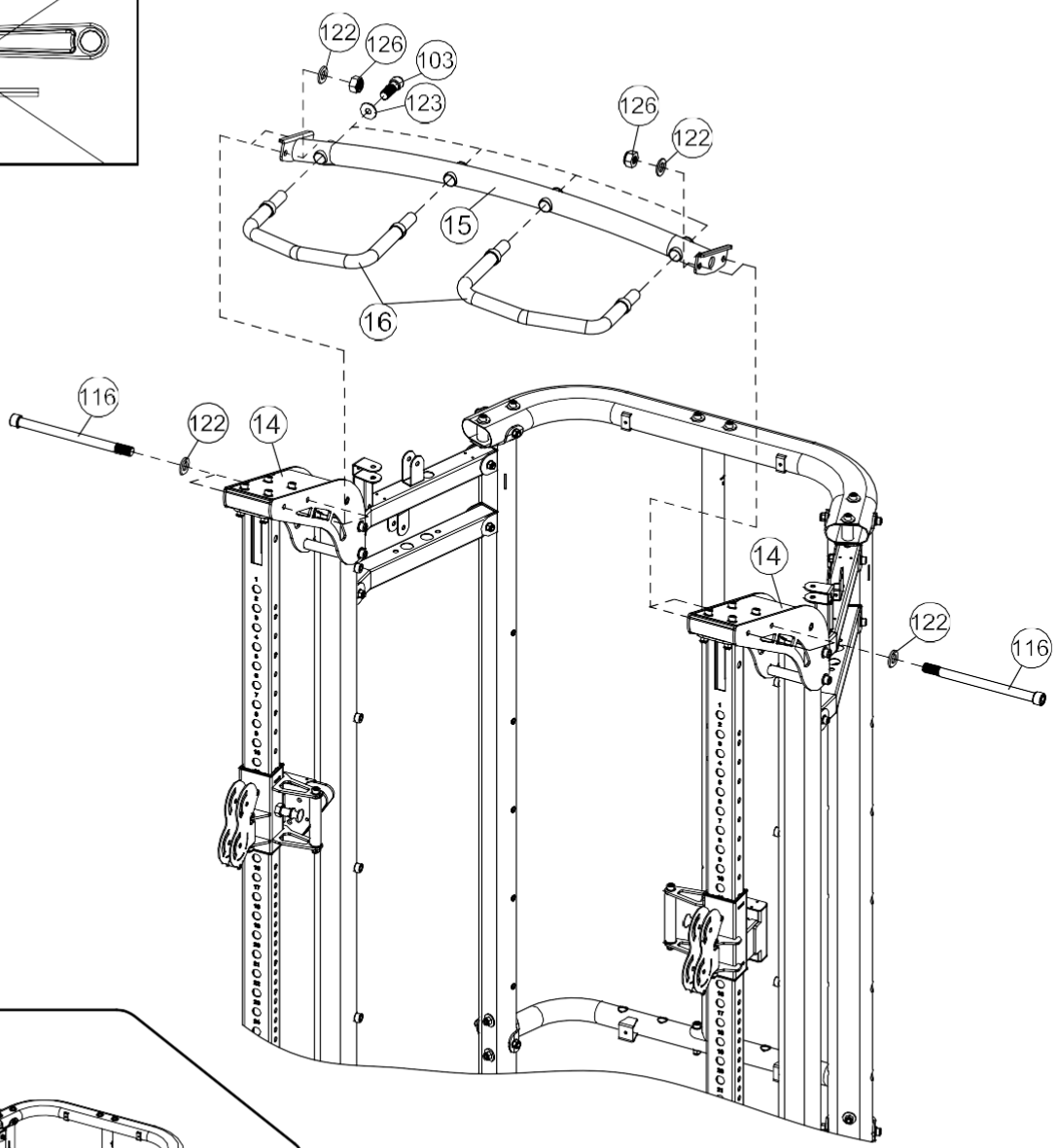
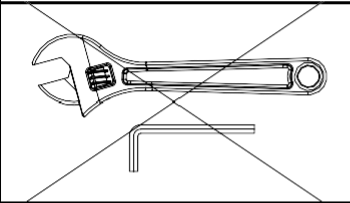

118

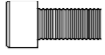

x10 M12x25

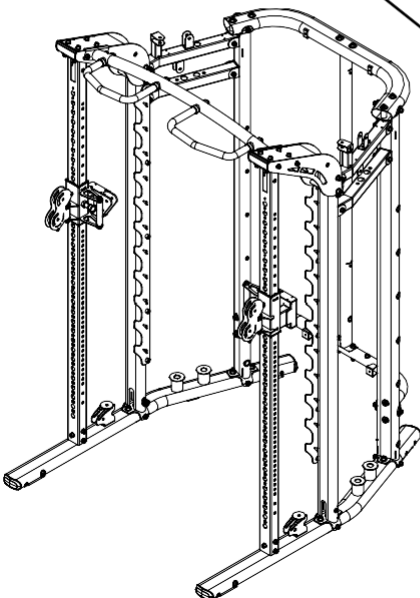
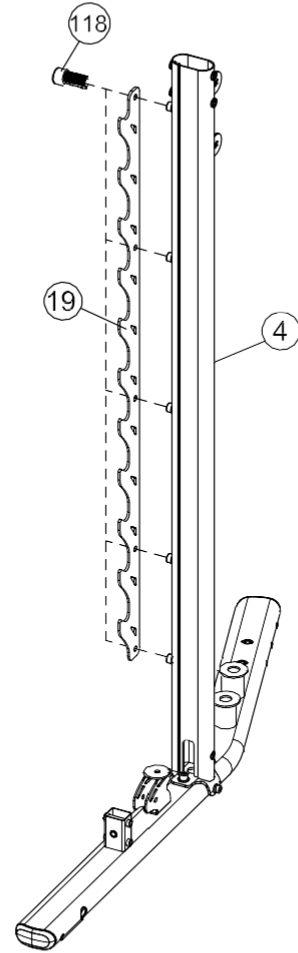
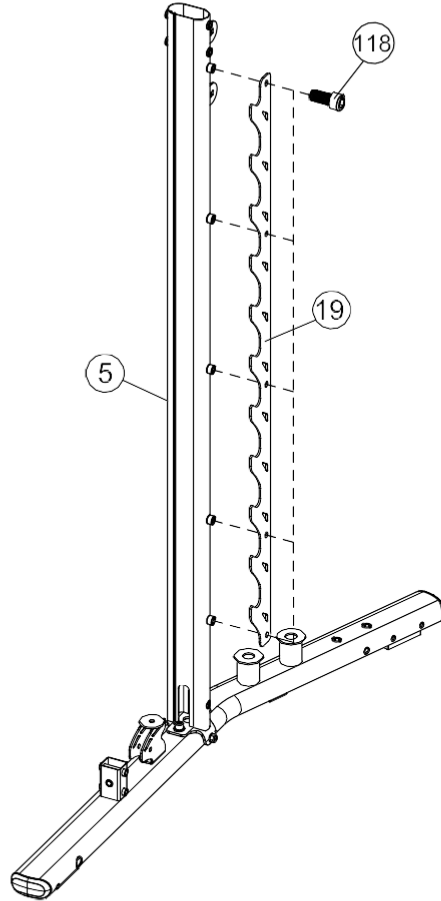
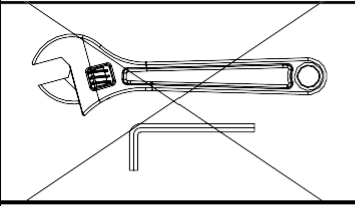

102



x4

M10x20







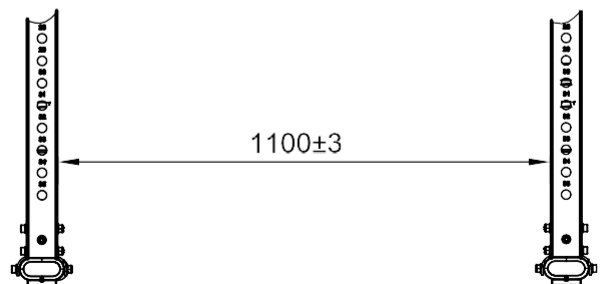
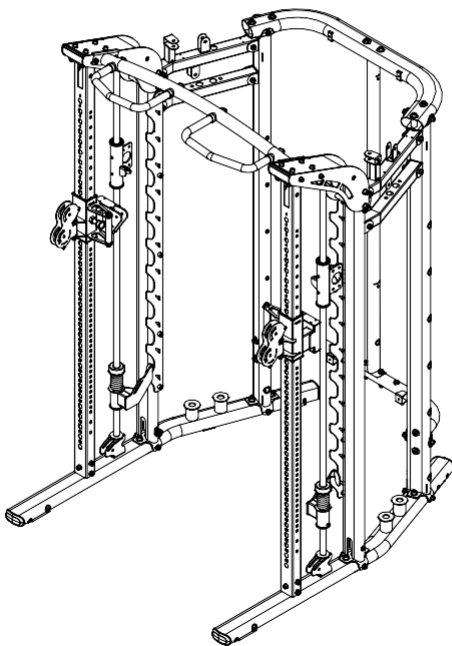
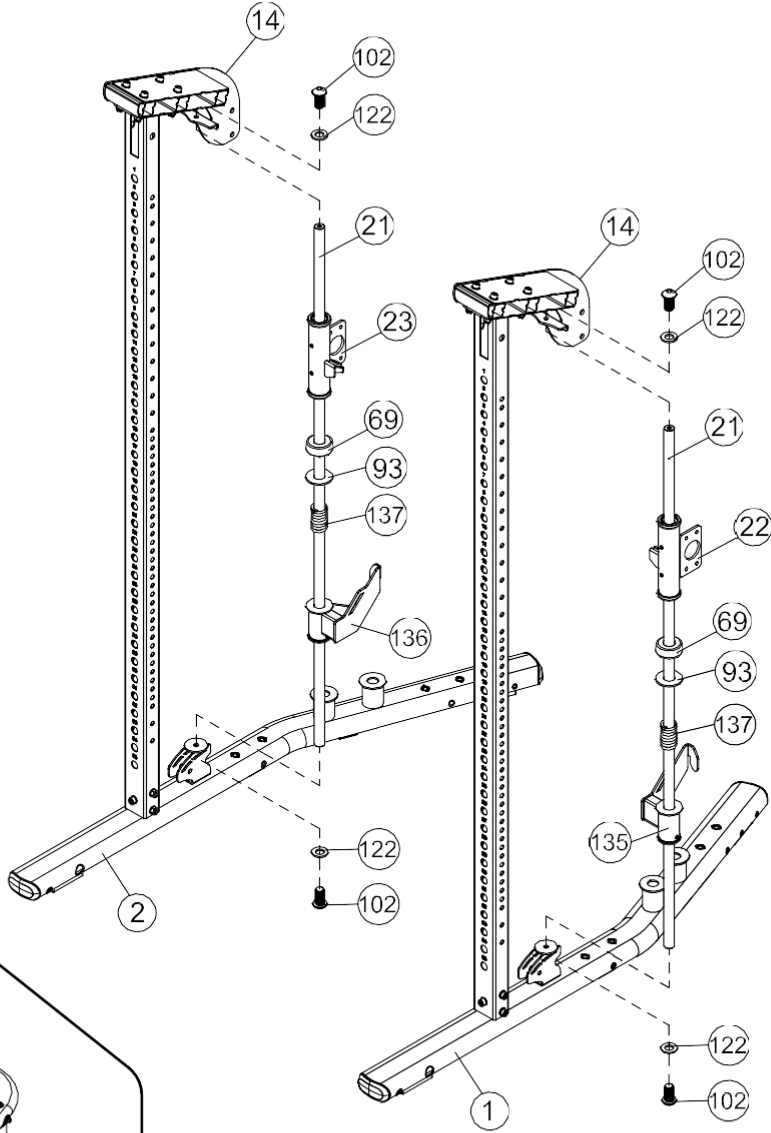
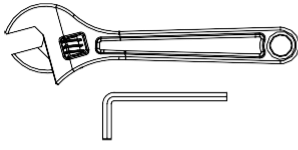

122



x4

Φ10



⑨⑨		×2	M8×20	⑩⑩		×8	M8×30
⑩①		×2	M8×30	⑫①		×16	Φ8
⑫⑤	 	×8	M8	⑫⑧		×2	Φ8
⑫⑨	 	×2	R20×φ9	⑦⑦		×2	Φ30×Φ9

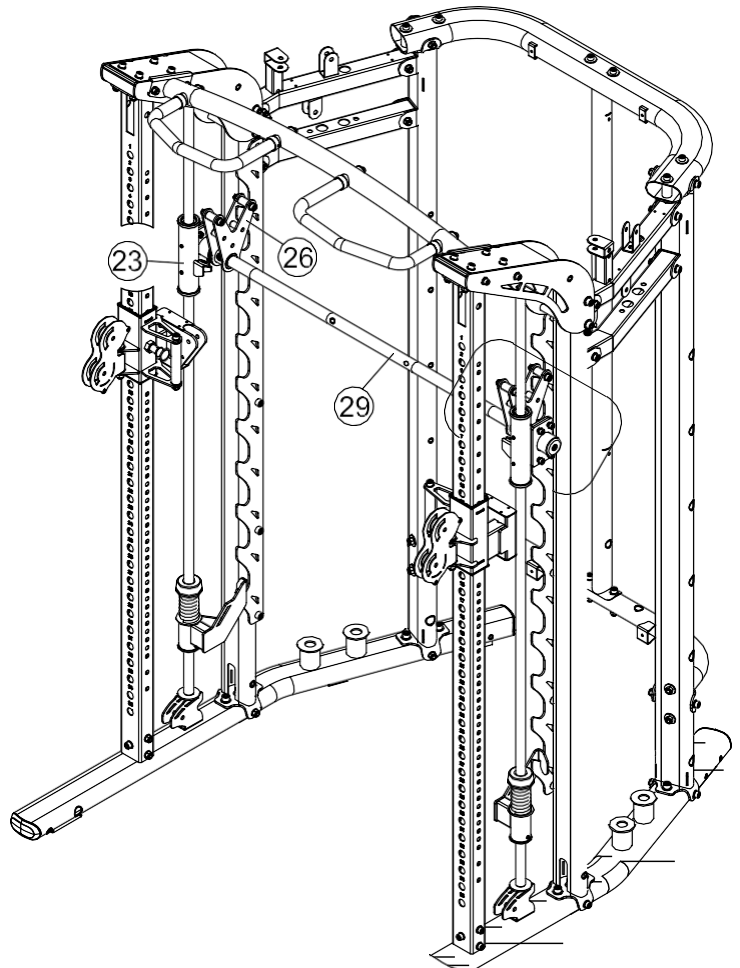
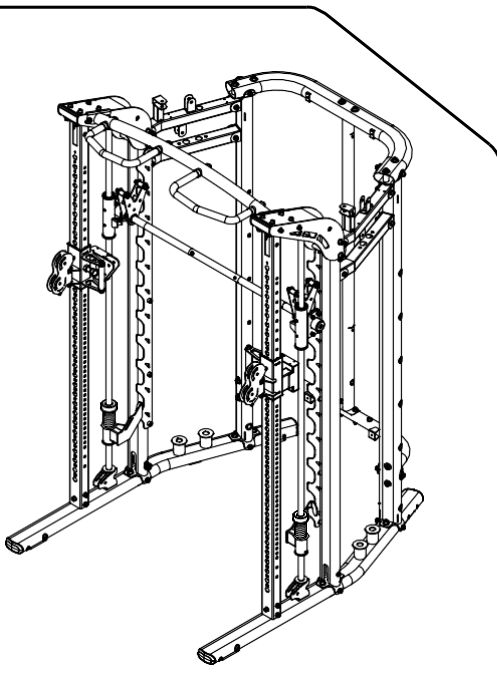
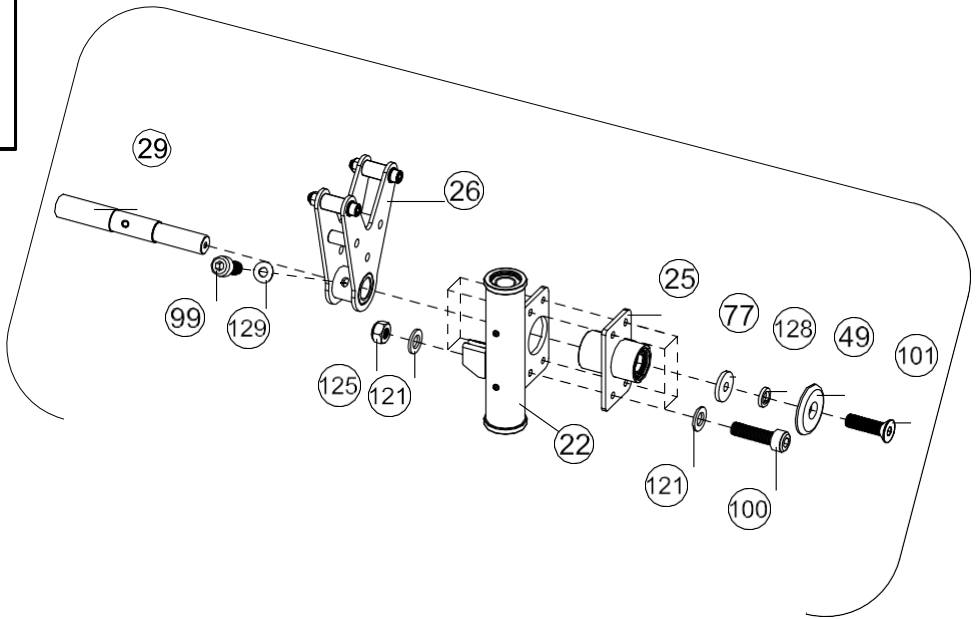
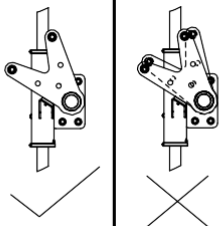
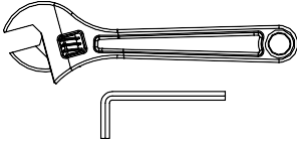

106



x2

M10x55

108

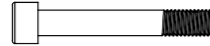

x4

M10x65

122



x4

Φ10

50



x2



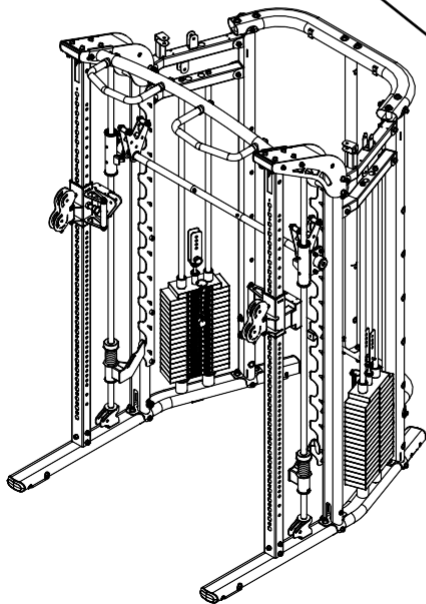
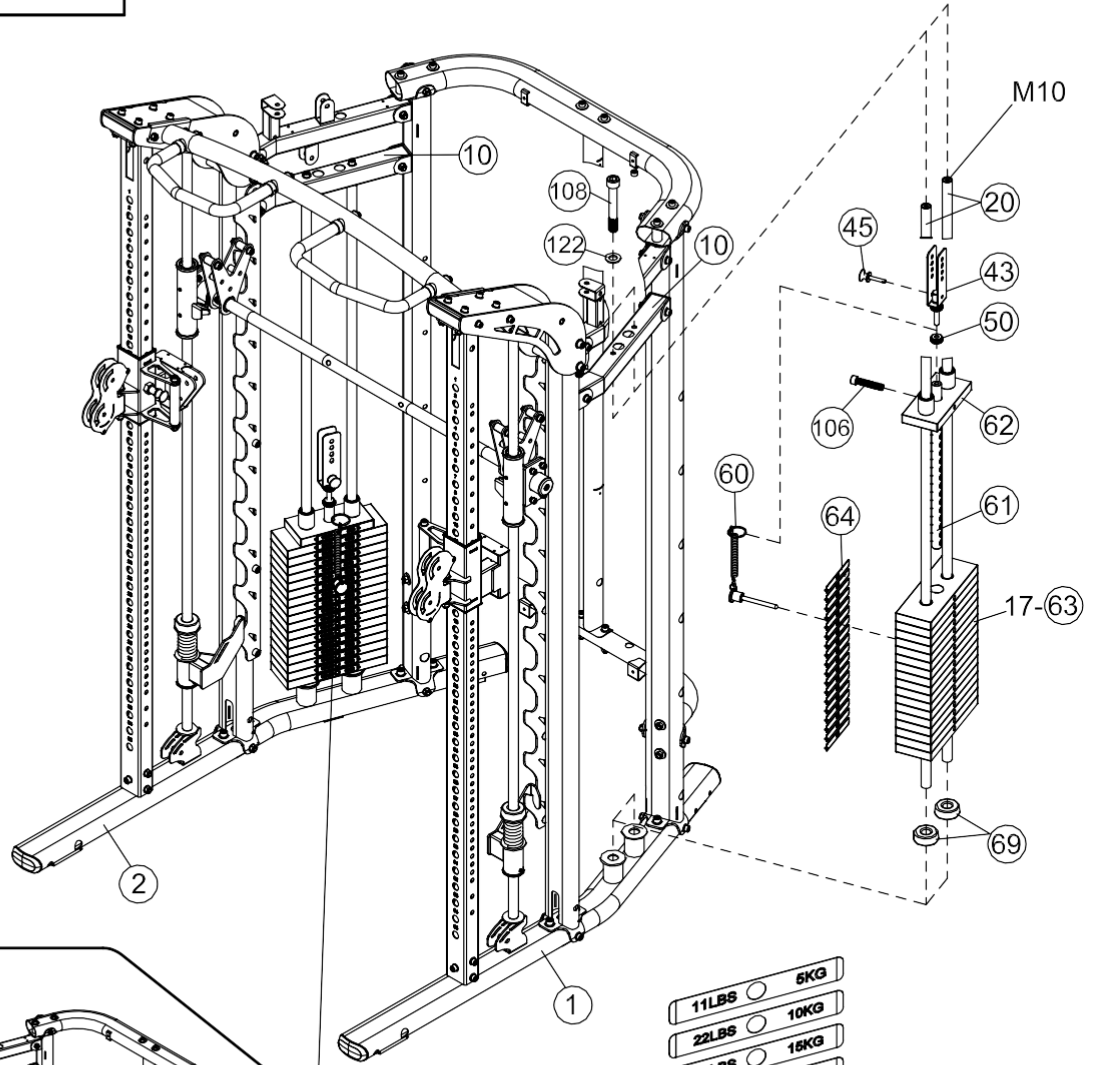
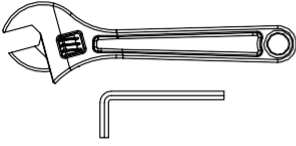

Φ28x12xM12

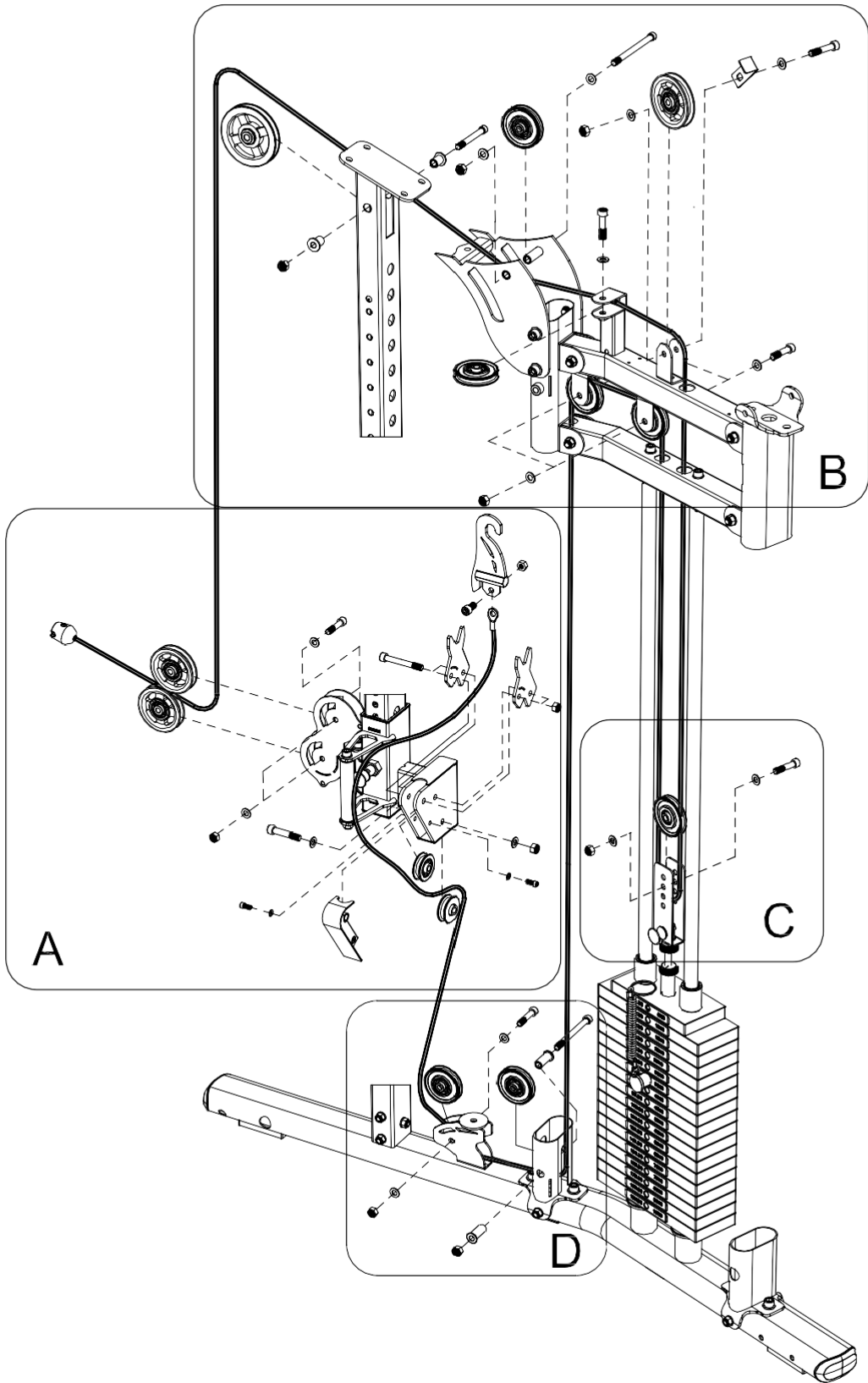

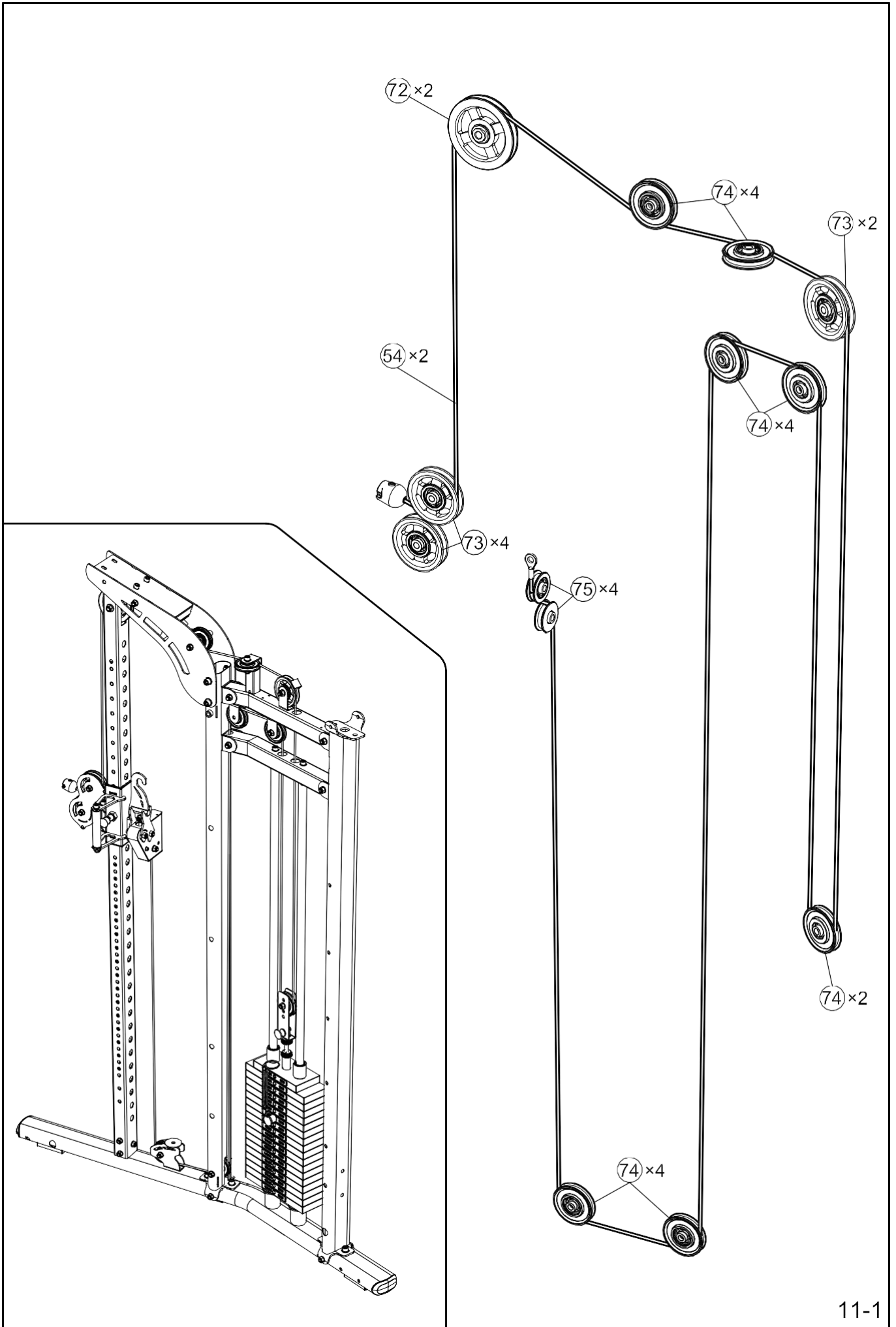



- 11LBS ○ 5KG
- 22LBS ○ 10KG
- 33LBS ○ 15KG
- 44LBS ○ 20KG
- 55LBS ○ 25KG
- 66LBS ○ 30KG
- 77LBS ○ 35KG
- 88LBS ○ 40KG
- 99LBS ○ 45KG
- 110LBS ○ 50KG
- 121LBS ○ 55KG
- 132LBS ○ 60KG
- 143LBS ○ 65KG
- 154LBS ○ 70KG
- 165LBS ○ 75KG
- 176LBS ○ 80KG
- 187LBS ○ 85KG
- 198LBS ○ 90KG





- ⑨⑥  x4 M6×15
- ⑩④  x4 M10×45
- ⑩⑥  x2 M10×55
- ⑩⑦  x4 M10×60

- ⑪①  x2 M10×20
- ⑫②  | x4 Φ6
- ⑫②  | x12 Φ10
- ⑫⑥   x12 M10

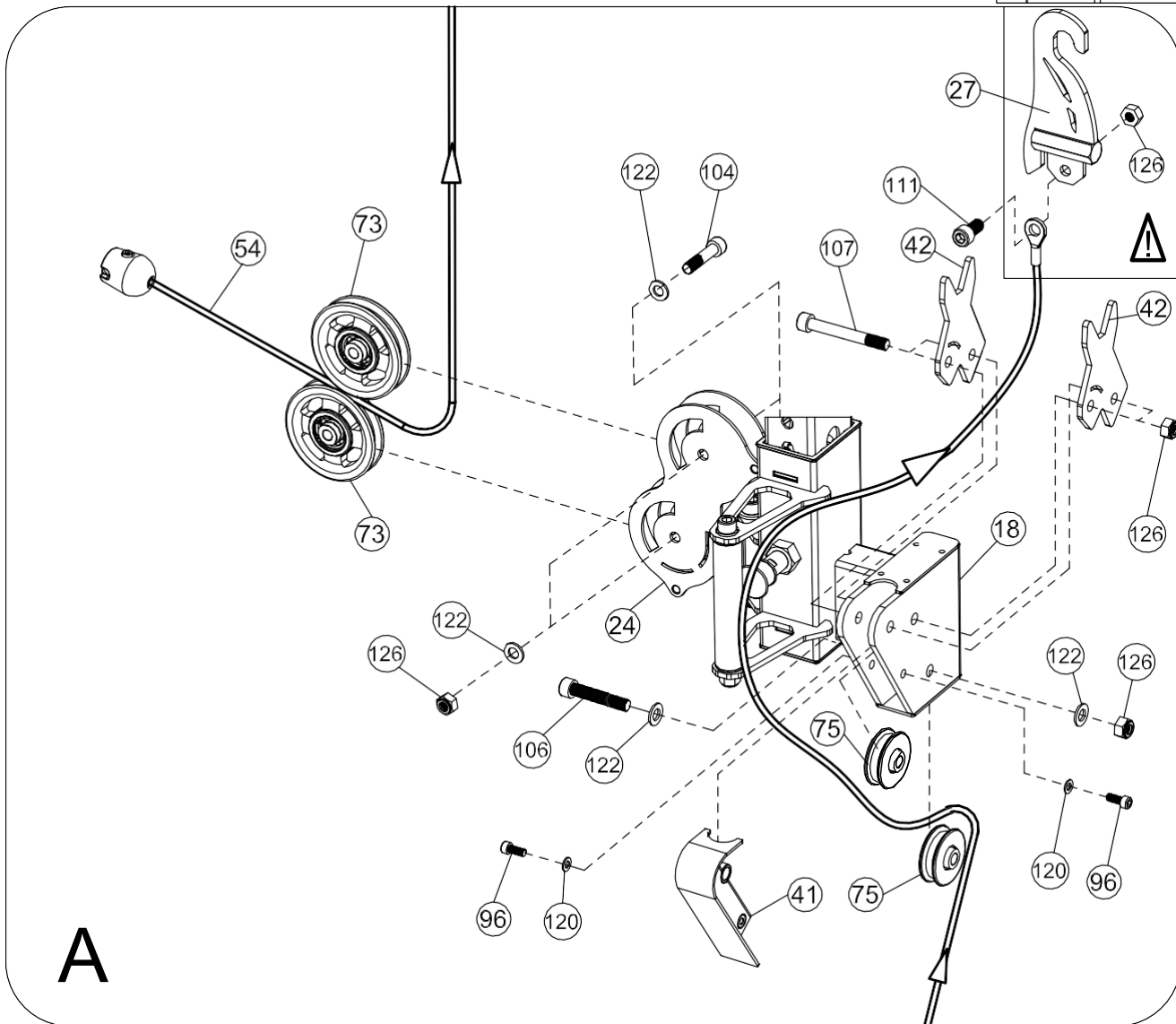
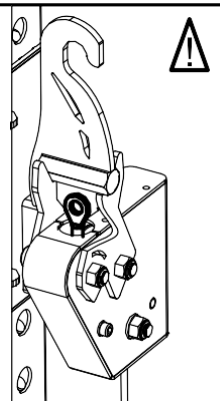
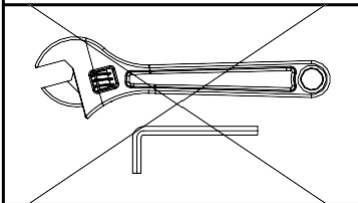





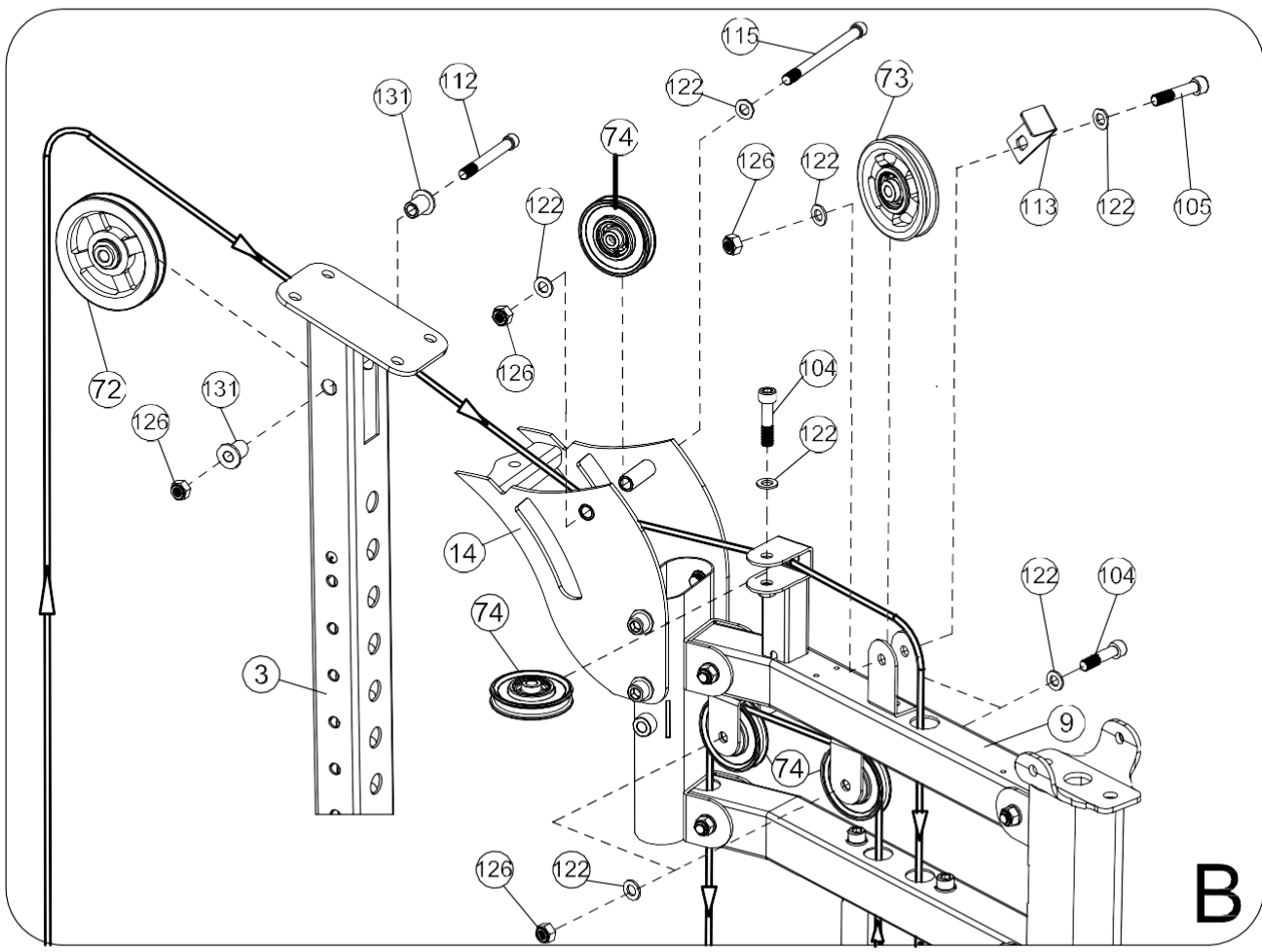
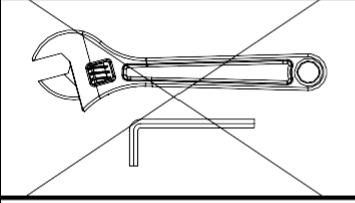

A

11-A

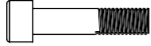
⑩④		x6	M10x45	⑩②		x18	Φ10
⑩⑤		x2	M10x50	⑩⑥		x10	M10
⑩②		x2	M10x85	⑩③		x4	Φ25xΦ10.2
⑩⑤		x2	M10x135				

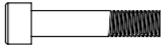

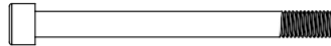



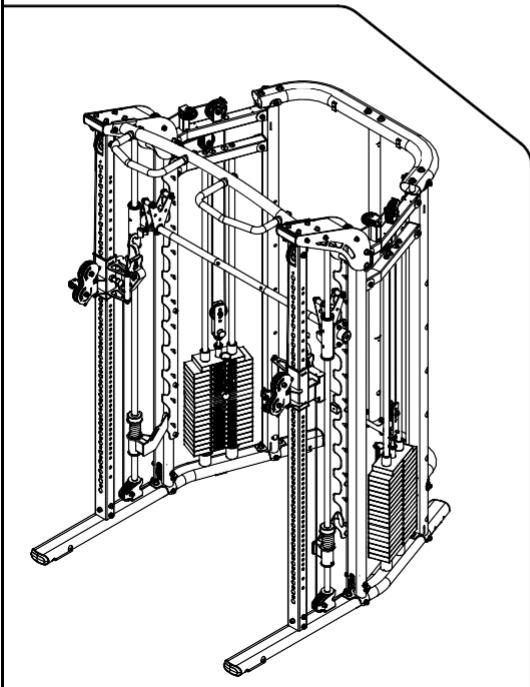
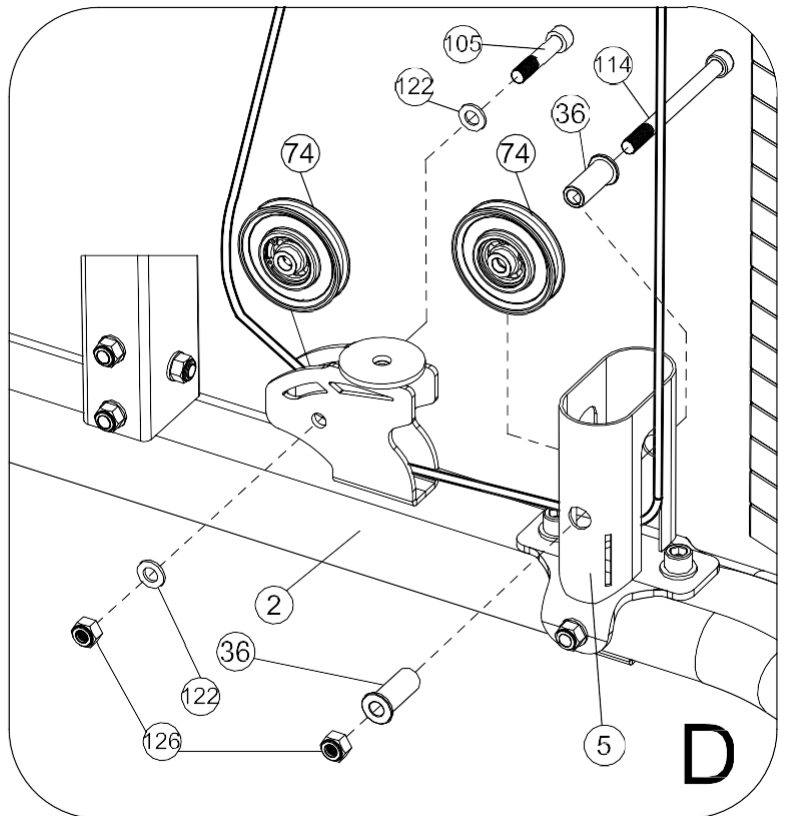
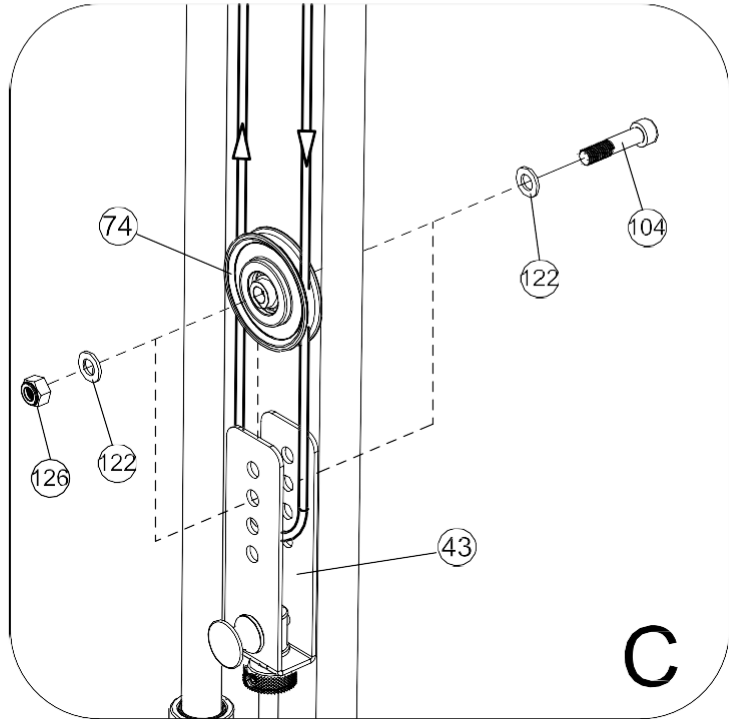
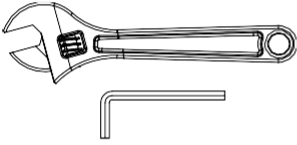

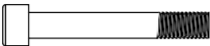

B

- | | | | | | | | | |
|----|---|----|---------|----|---|---|----|---------------|
| ⑩④ |  | ×2 | M10×45 | ⑩② |  | | ×8 | Φ10 |
| ⑩⑤ |  | ×2 | M10×50 | ⑩⑥ |  |  | ×6 | M10 |
| ⑩④ |  | ×2 | M10×115 | | | | | |
| ③⑥ |  | | | ×4 | |  | | Φ22×Φ16×Φ10.5 |



11-C
11-D

96		×6	M6×15	120			×8	Φ6
109		×2	M10×70	122			×4	φ10
134	 	×2	M6	126			×2	M10

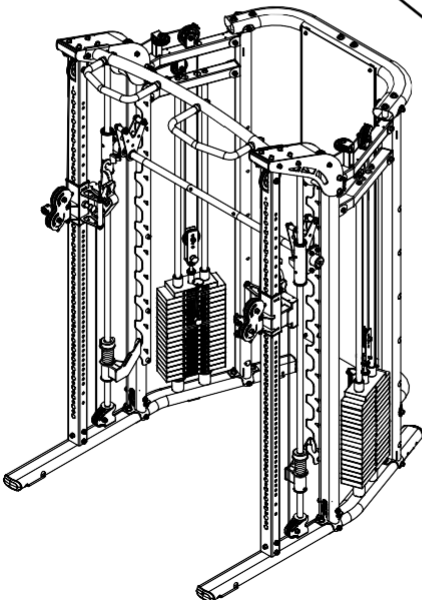
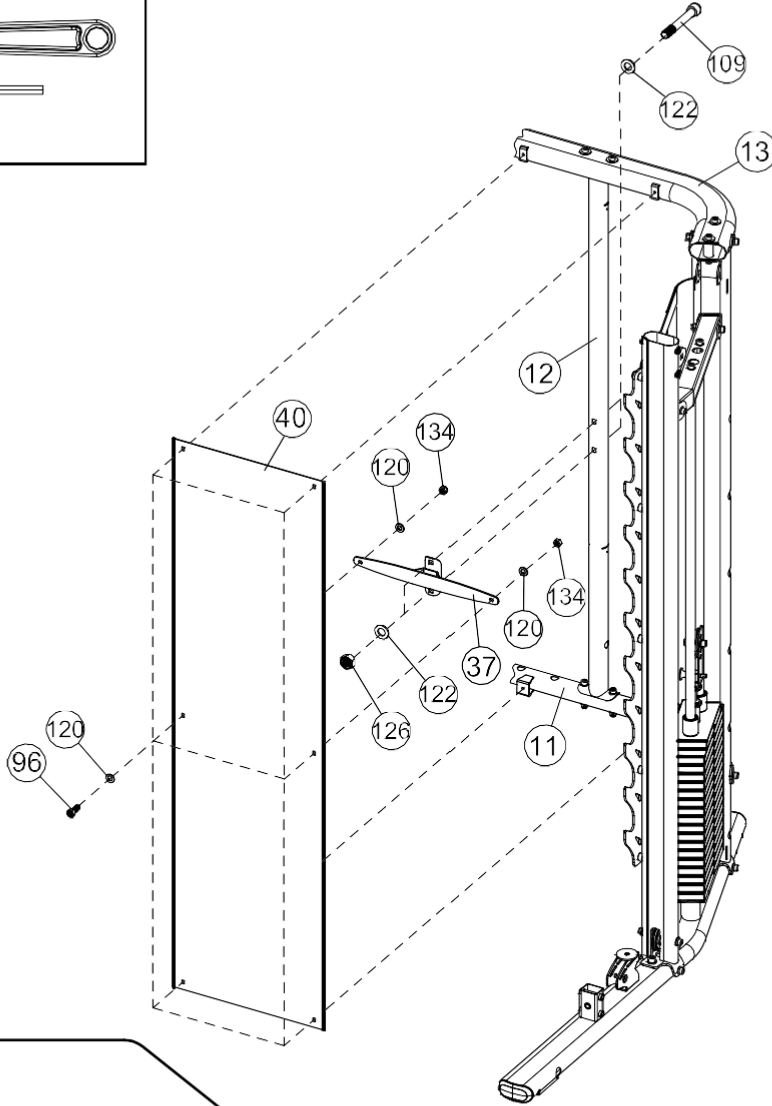
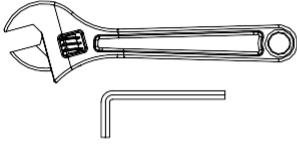

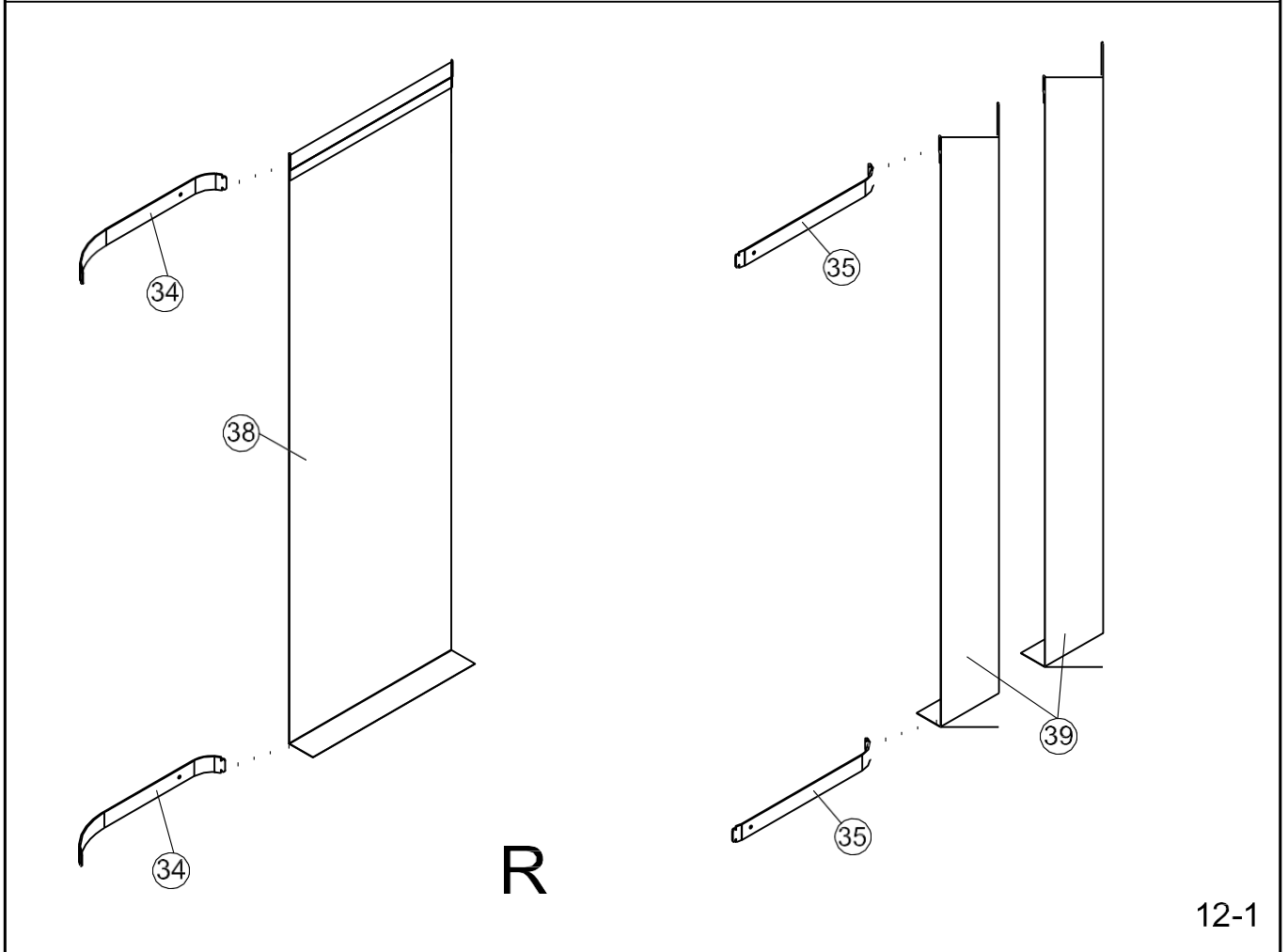
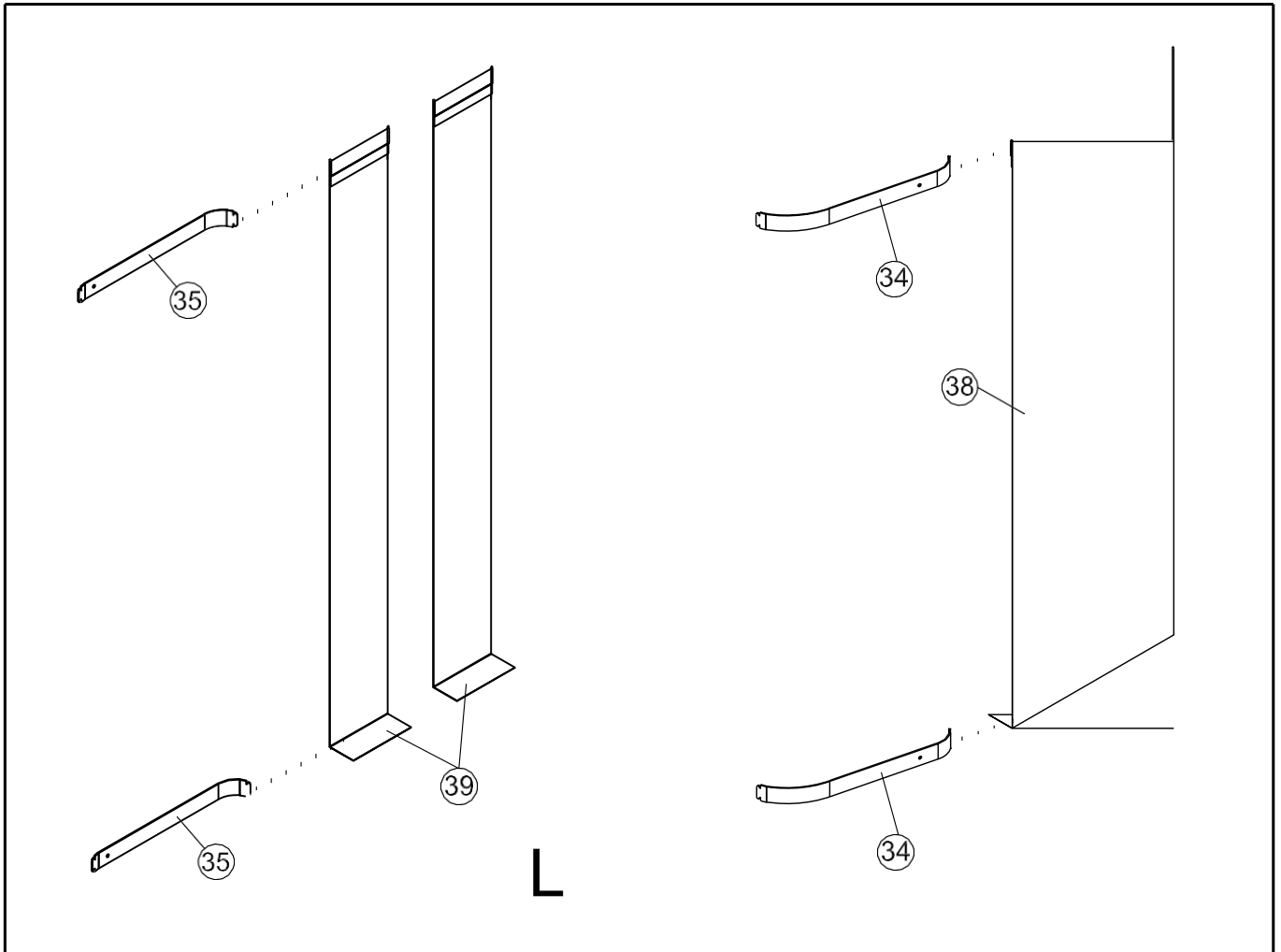

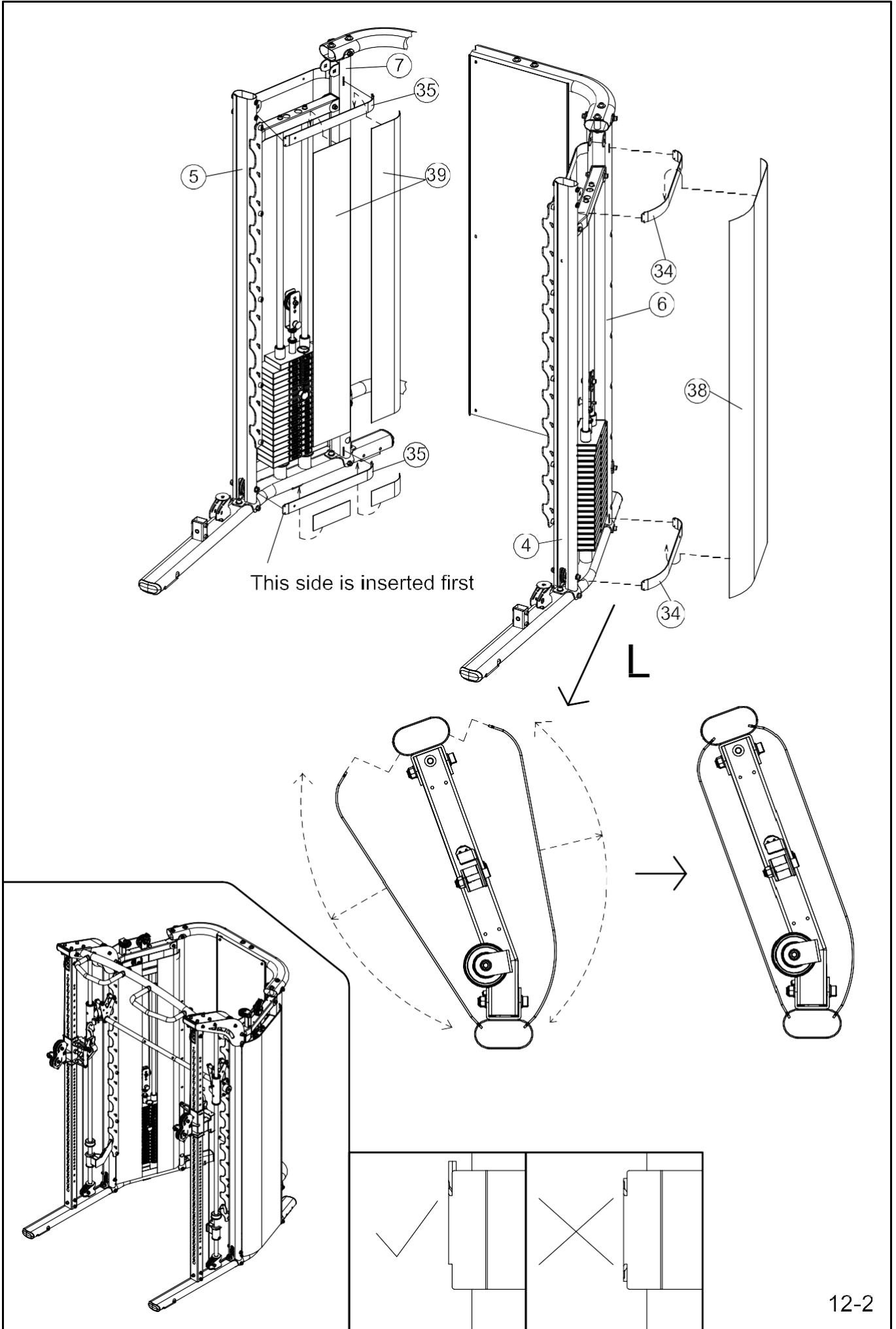

96



x24 M6x15

120



x24

Φ6

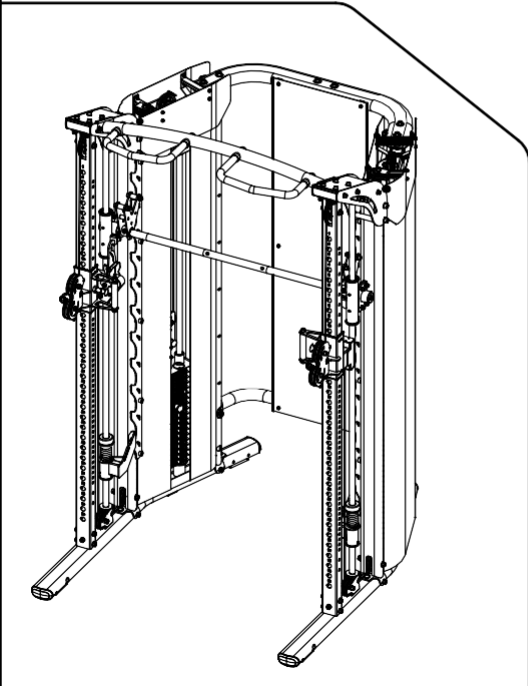
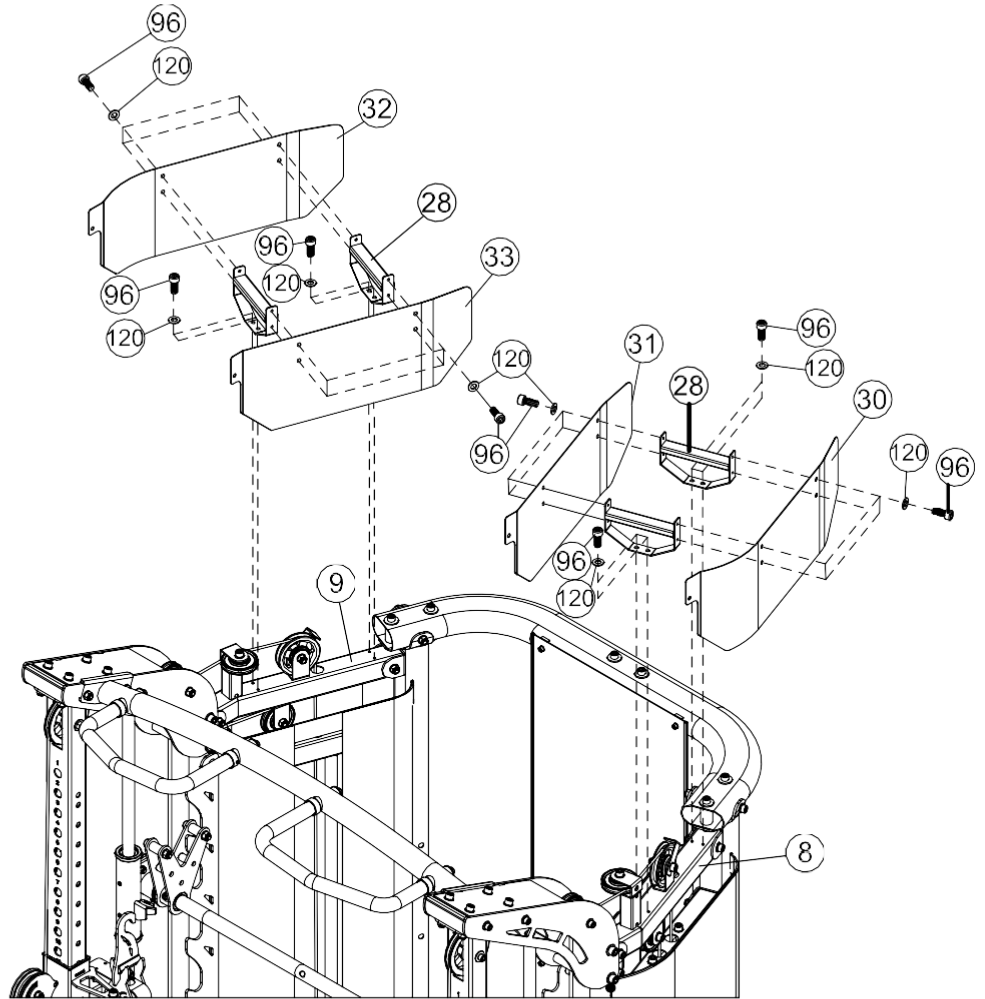
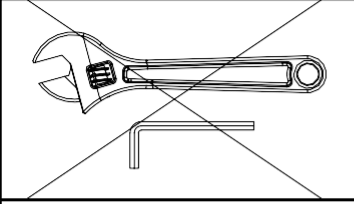

92



×10 ST4.8×13

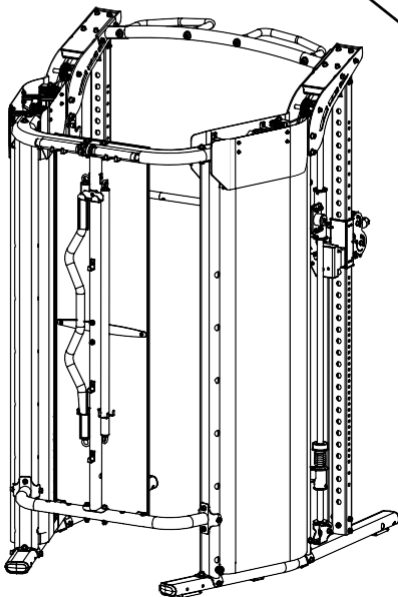
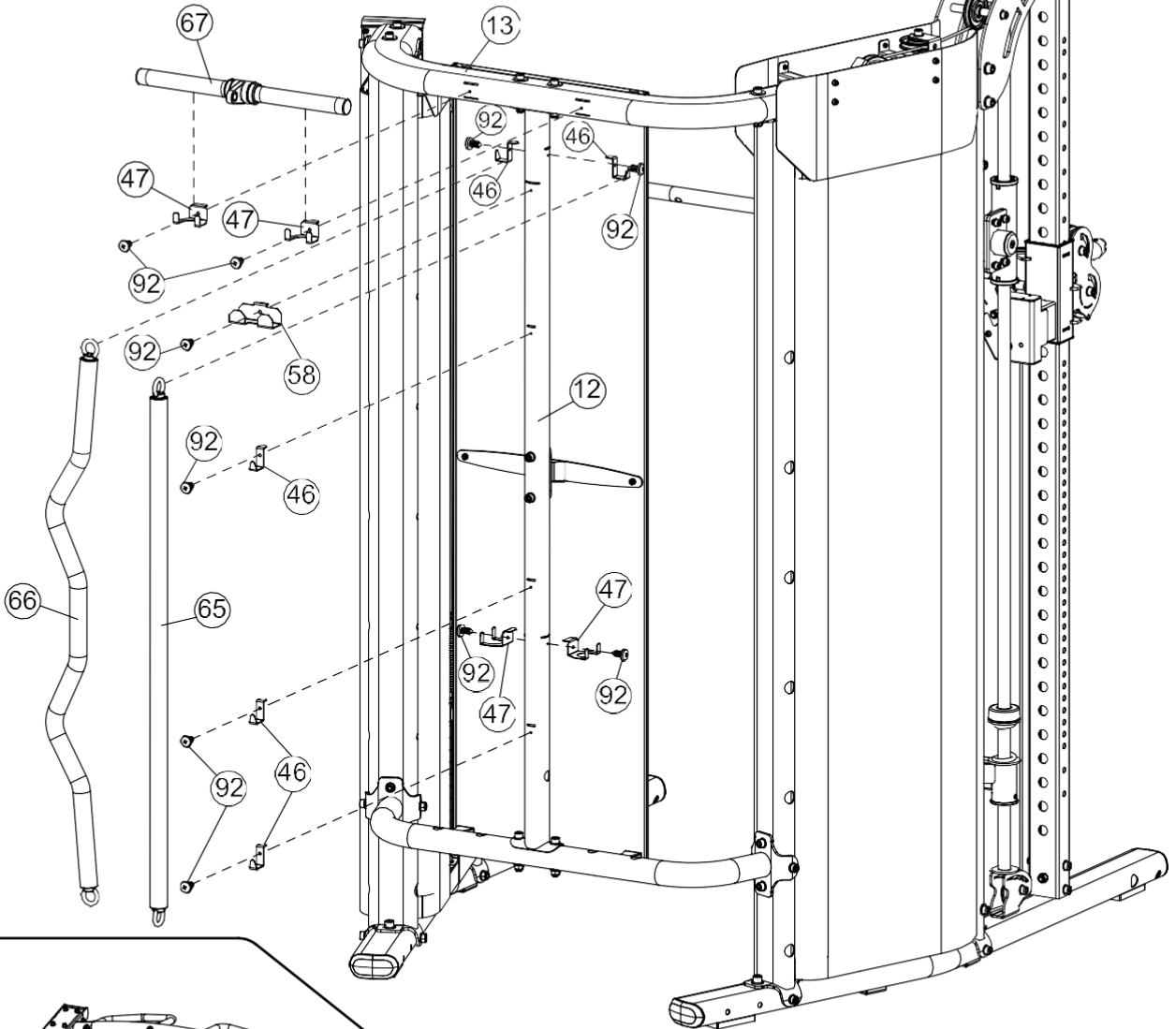
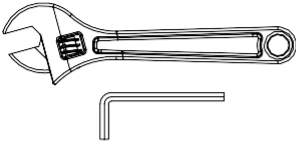

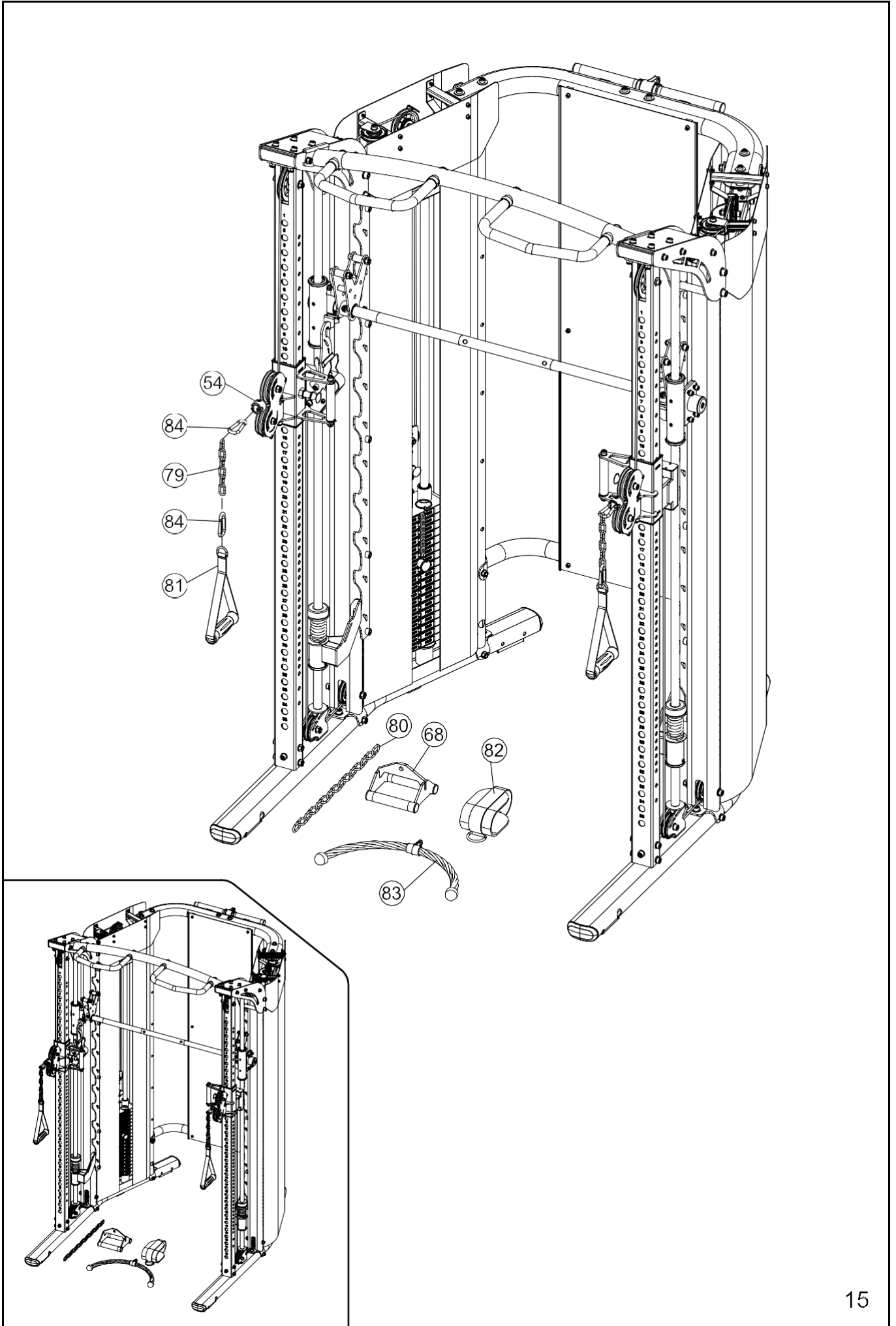

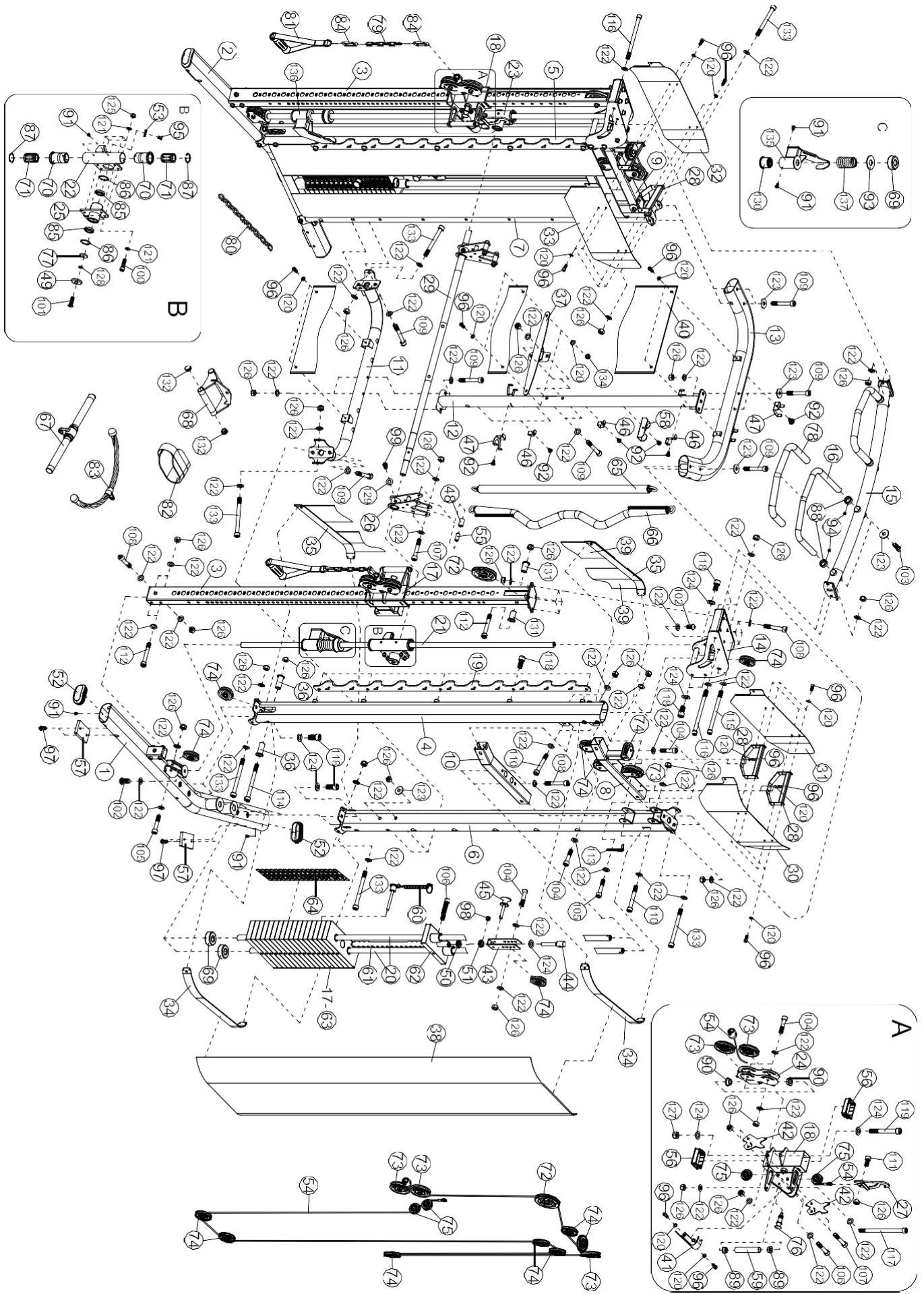

PARTS LIST

KEY NO.	PART DESCRIPTION	SPEC	QTY
1	Base Frame L		1
2	Base Frame R		1
3	Guide Shaft		2
4	Front Post L		1
5	Front Post R		1
6	Rear Post L		1
7	Rear Post R		1
8	Top Frame L		1
9	Top Frame R		1
10	Fixed Frame	□50×2× (480)	2
11	Lower Connecting Frame		1
12	Intermediate Frame		1
13	Upper Connecting Frame		1
14	Front Connecting Frame		2
15	Horizontal bar		1
16	Chin-up Bar		2
17	Sliding frame L		1
18	Sliding frame R		1
19	Plate	1470×92×5	2
20	Guide Rod Rear	φ25×1580	4
21	Guide Rod	φ25×1815	2
22	Mobile rack L		1
23	Mobile rack R		1
24	Pulley Case		2
25	Connecting Frame		2
26	Hanging Bracket		2
27	Lifting Frame		2
28	Inner Fixed Set		4
29	Weight Rod	φ30×1260×M8	1
30	Outer Guard Plate L	608×220×79×1.5	1

PARTS LIST

KEY NO.	PART DESCRIPTION	SPEC	QTY
31	Inner Guard Plate L	560×220×28×1.5	1
32	Outer Guard Plate R	608×220×79×1.5	1
33	Inner Guard Plate R	560×220×28×1.5	1
34	Outer Guard Plate	519×82×45×3	4
35	Inner Guard Plate	493×50×45×3	4
36	Bushing	φ22×φ16×φ10.2×40	4
37	Supporting Frame		1
38	Outer Cover	1875×545	2
39	Inner Cover	1875×195	4
40	Rear Cover		1
41	Small Cover Frame		2
42	Supporting Plate	122×79×5	4
43	Pulley Case	160×50×25×3	2
44	Adjusting Bolt	φ22×100×M12	2
45	Aluminum Alloy Pin		2
46	Upper Handle Fixing Base	50×42×16×2	5
47	Lower Handle Fixing Base	61×60×30×1.5	4
48	Stainless Bushing	φ20×1.5×33	4
49	Aluminum Alloy End Cover	φ50×φ9×6	2
50	Knurled Nut	φ28×12×M12	2
51	Adjusting Sleeve	φ28×φ12.5×12	2
52	End Cap	PT50×100×R95	4
53	Rack Liner	φ30×5	2
54	Pull cable	L=φ5×7170	2
55	Bushing	φ16×φ11×33	4
56	Hollow Sleeve	□60×80×2.0×□50×70	4
57	Rubber Stopper	65×100×12	4
58	Small Storage Rack	100×37×38×27×10×2	1
59	Knurled Handle	φ25×2×125	2
60	Weight Selector Pin		2

PARTS LIST

KEY NO.	PART DESCRIPTION	SPEC	QTY
61	Selector Rod	φ25×513 (17+1)	2
62	Top Weight Plate	205×100×72	2
63	Weight Plate	280×100×25.4 (5KG)	34
64	Weight Plate Sticker(90kg)	119×17.5	2
65	Aluminum Straight Bar	L=1115mm	1
66	Aluminum Cambered Bar	L=1150mm	1
67	Aluminum Small Grip Bar	L=480mm	1
68	V-type handle		1
69	Rubber Stopper	φ62×φ24.5×25	6
70	Sliding Rod Guide	φ55×φ46×φ40×73	4
71	Linear Motion Bearing	LB254058	4
72	Pulley with Bearings	φ114×φ10	2
73	Pulley with Bearings	φ95×φ10	6
74	Pulley with Bearings	φ72×φ10	14
75	Pulley with Bearings	φ50×φ10	4
76	Moving Lock Pin		2
77	Inner Washer	φ30×φ9×4	2
78	Long Rubber Handle	φ24.5×580	2
79	6-Joint Chain		2
80	15-Joint Chain		1
81	Pulling Sleeve	L=245mm	2
82	Ankle Strap		1
83	Rope		1
84	Hook	φ8	4
85	Bearing	61905	4
86	Hole circlip	42	4
87	Hole circlip	d0=40	4
88	Hole circlip	φ35×φ26.2×14.5×M6	4
89	Bushing	φ25×φ21.8×φ10.5×12	4
90	Bushing	φ25×φ20×φ12.2×10	4

PARTS LIST

KEY NO.	PART DESCRIPTION	SPEC	QTY
91	Screw	ST4.0×9	12
92	Screw	ST4.8×13	10
93	Plate	φ65×φ27×4	2
94	Set screw	M6×6	4
95	Allenllen Bolt	M4×10	2
96	Hexagon socket button head screws	M6×15	34
97	Allen Bolt	M8×16	8
98	Set screw	M8×8	2
99	Hexagon socket button head screws	M8×20	2
100	Hexagon socket button head screws	M8×30	8
101	Hexagon socket countersunk head screw	M8×30	2
102	Allen Bolt	M10×20	4
103	Hexagon socket button head screws	M10×25	4
104	Hexagon socket button head screws	M10×45	12
105	Hexagon socket button head screws	M10×50	4
106	Hexagon socket button head screws	M10×55	4
107	Hexagon socket button head screws	M10×60	8
108	Hexagon socket button head screws	M10×65	14
109	Hexagon socket button head screws	M10×70	14
110	Hexagon socket button head screws	M10×75	8
111	Hexagon socket button head screws	M10×20	2
112	Hexagon socket button head screws	M10×85	6
113	L-Plate	72×30×25×2.5	2
114	Hexagon socket button head screws	M10×115	2
115	Hexagon socket button head screws	M10×135	2
116	Hexagon socket button head screws	M10×140	4
117	Hexagon socket button head screws	M10×155	2
118	Hexagon socket button head screws	M12×25	26
119	Hexagon socket button head screws	M12×95	2
120	Washer	6	36

PARTS LIST

KEY NO.	PART DESCRIPTION	SPEC	QTY
121	Washer	8	16
122	Washer	φ10	144
123	Washer	φ30×φ10.5×2.5	14
124	Washer	12	22
125	Nut	M8	8
126	Nut	M10	82
127	Nut	M12	2
128	Spring Washer	8	2
129	Bend Washer	20×R20×φ9	2
130	Sliding Sleeve	φ55×φ46×φ27×41	2
131	Pulley Bushing	φ25×φ10.2×24	4
132	End Cap	φ28	4
133	Hexagon socket button head screws	M10×125	8
134	Nut	M6	2
135	Safety Bracket L		1
136	Safety Bracket R		1
137	Spring	φ43×φ27×φ8×80	2
	Allen wrench	3#	1
	Allen wrench	4#	1
	Allen wrench	5#	1
	Allen wrench	6#	1
	Allen wrench	8#	1
	Allen wrench	10#	1